

Nikon

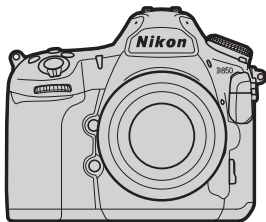

D850

**Professional
Technical Guide**
— Useful Features —

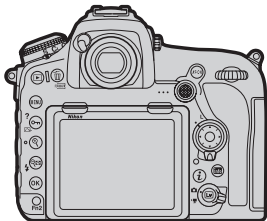

En

Table of Contents

Live View: Pinpoint AF	4
Focus Stacking (Focus Shift Photography)	8
• “Focus Shift Shooting”	10
• Before Shooting	12
• Focus Shift Photography.....	13
• Suggested Settings	16
• Choosing the Number of Shots.....	18
• Focus Shift: Tips.....	21
• Before Stacking	22
• Some Examples of Focus Stacking	23
White Balance Tips and Tricks	25
• White Balance Options.....	25
• Auto White Balance for Incandescent Lighting.....	27
• Natural Light Auto	28
• Color Temperature Information	29
• Measuring Preset Manual White Balance	30
Digitizing 35 mm Film	32
• What You’ll Need.....	33
• Handling Film	36
• Digitizing Negatives.....	36
• Digitizing Positives (Slides)	39
• Retouching Digitized Photos	41

Muffling the Shutter	44
• “Quiet” Versus “Silent”	44
• Quiet Shutter-Release Mode.....	45
• Silent Photography	46
• Movie Stills	47
Focus Peaking	48
Cropping and Zoom	49
On-Camera Batch NEF (RAW) Processing	50
• The Benefits of On-Camera Processing	50
• On-Camera NEF (RAW) Processing	51
Auto AF Fine-Tuning	56
Unavailable Menu Options	59
• The Photo Shooting Menu	59
• The i -Button Menu (Live View Photography).....	60

Live View: Pinpoint AF

The D850's live view features a new pinpoint AF-area mode for more precise focus than ever before.

Pinpoint AF: The camera focuses precisely on the intended point (in this case, the stamens).

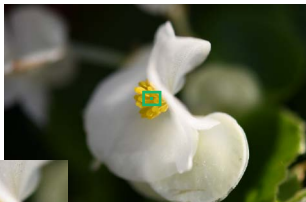

Intended focus point (enlarged)

Normal-area AF: The wider focus area may result in the camera not focusing on the intended point.

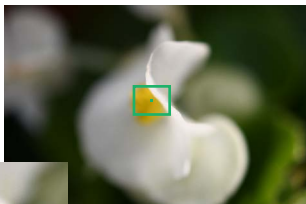

Intended focus point (enlarged)

Follow the steps below to take pictures using pinpoint AF. Before proceeding, we recommend that you mount the camera on a tripod and select single-servo autofocus (AF-S).

1 Start live view.

Pinpoint AF is available in live view only. Press the **[Lv]** button to start live view.

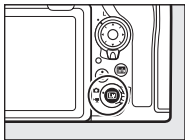

2 Select $\left[\begin{smallmatrix} \text{AF} \\ \text{PIN} \end{smallmatrix} \right]$.

Keeping the AF-mode button pressed, rotate the sub-command dial until $\left[\begin{smallmatrix} \text{AF} \\ \text{PIN} \end{smallmatrix} \right]$ (pinpoint AF) appears in the display.

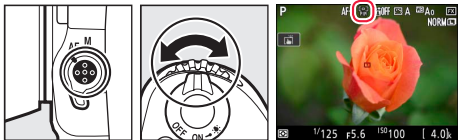

3 Position the focus point.

Use the multi selector or touch controls to position the focus point, or press the center of the multi selector to return the focus point to the center of the frame.



4 Zoom in.

For greater accuracy, press the  button to zoom in on the selected focus point.

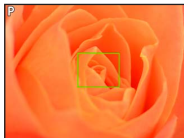

5 Take the picture.

Although you can take pictures using the shutter-release button, to prevent blur caused by camera shake we recommend that you use the remote photography feature in the SnapBridge app or an optional accessory such as a wireless remote controller or remote cord.

Touch Controls

When using touch controls to position the focus point, note that at default settings, the shutter will be released when you lift your finger from the display ("touch shutter"); for more accurate focus, tap the touch shutter icon to turn the touch shutter off (OFF).



Focus Stacking (Focus Shift Photography)

“Focus stacking” combines photos shot at different focus positions into a single image with increased depth of field. The D850’s new focus shift feature, which automatically varies focus over a series of shots, is used to take photos that will later be combined using focus stacking.



Normal photograph



*Focus-stacked image
(for camera settings, see [page 23](#))*



Normal photograph



*Focus-stacked image
(for camera settings, see [page 24](#))*

When shooting is complete, you can copy the photos to a computer and use third-party focus-stacking software to combine the areas that are in focus into a single image.

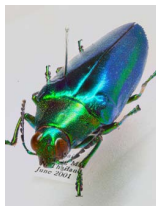
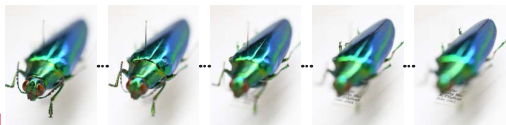

The camera takes a series of shots (150 in this example), which are used to create a composite image containing only the areas that are in focus.

Focus-Stacking Software

The following applications support focus stacking. *Note that Nikon neither endorses this software nor guarantees its operation.*

- Adobe: Photoshop CC
- Helicon Soft: Helicon Focus
- Zerene Systems: Zerene Stacker

“Focus Shift Shooting”

The **Focus shift shooting** item in the photo shooting menu is used to adjust settings for focus shift photography. The following options are available:

- **Start:** Start shooting. The camera will change the focus distance by the selected amount with each shot.
- **No. of shots:** Choose the number of shots (up to 300) that you will need when performing focus stacking.
- **Focus step width:** Choose the amount the focus distance changes with each shot. The options available range from 1 to 10: choose lower values for smaller steps, higher values for larger steps.
- **Interval until next shot:** The time between shots, in seconds. Select **00** to take photos at approximately 5 fps (release modes **S**, **CL**, **CH**, and **MUP**) or 3 fps (release modes **Q** and **Qc**).
- **Exposure smoothing:** If **On** is selected, the camera will adjust the exposure for each new shot to match the immediately preceding shot.
- **Silent photography:** Select **On** to silence the shutter during shooting.

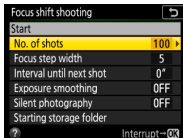

- **Starting storage folder:** Highlight options and press  to select or deselect. Choose **New folder** to create a new folder for each new focus shift sequence, **Reset file numbering** to reset file numbering to 0001 when a new folder is created.

● **Before Shooting**

Use an AF-S or AF-P lens. After mounting the appropriate lens, choose an exposure mode of **A** or **M** so that aperture does not change during shooting (recommended). Once settings have been adjusted to your satisfaction, close the viewfinder eyepiece shutter to prevent light entering via the viewfinder interfering with photographs and exposure.

Before shooting begins, mount the camera on a tripod, disable lens vibration reduction (VR), and select a release mode other than . To ensure that shooting is not interrupted, be sure the camera battery is fully charged. If in doubt, charge the battery before use or use an AC adapter and power connector (available separately).

Focus shift is available at all image quality settings. Note that focus shift is unavailable in some situations, including when multiple exposure or HDR shooting is in progress, the camera clock is not set, an incompatible lens is attached, or no memory card is inserted.

● Focus Shift Photography

Follow the steps below to take photographs using focus shift.

1 Rotate the focus-mode selector to AF.

Focus shift is not available with manual focus lenses.

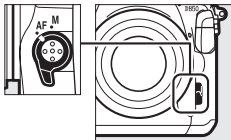

2 Focus.

The camera takes a series of shots starting from a selected focus position and continuing toward infinity. The starting focus position should be slightly in front of the closest point on the subject. Do not move the camera after focusing.

3 Select Focus shift shooting.

In the photo shooting menu, highlight **Focus shift shooting** and press  to display focus shift options.

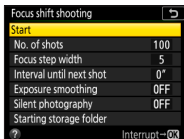
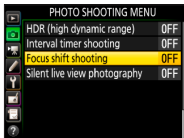

4 Adjust settings.

Adjust settings as described on [“Focus Shift Shooting”](#) (page 10). For more information, see [“Suggested Settings”](#) (page 16).

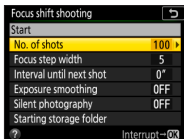

5 Start shooting.

Highlight **Start** and press **OK**. Shooting starts after about 3 s. The camera takes photographs at the selected interval, beginning at the focus distance selected at the start of shooting and progressing out toward infinity by the selected focus step distance with each shot. Shooting ends when the selected number of shots has been taken or focus reaches infinity. To end shooting before all shots have been taken, select **Off** for **Focus shift shooting** in the photo shooting menu or wait until the camera is between shots and then press **OK** or press the shutter-release button halfway.

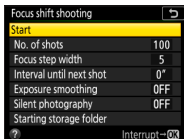

During Shooting

During focus shift photography, the **INTVL** icon will flash in the control panel. Immediately before the next shot, the shutter speed display will show the number of shots remaining.

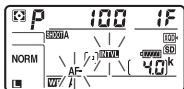

● Suggested Settings

For focus shift photography, we recommend that settings be adjusted as described below.

Aperture

For improved contrast out to the edges of the frame, we generally recommend an aperture 2 to 3 stops from the maximum for the lens.

ISO Sensitivity

We recommend that you select **Off** for **ISO sensitivity settings** > **Auto ISO sensitivity control** and do not change ISO sensitivity while shooting is in progress.

Focus Shift Settings

No. of shots: You may need over a 100 shots for a close-up or an insect or other small object, while only a few are required when photographing a landscape from front to back with a wide-angle lens. We recommend taking more shots than you think you'll need and winnowing them down during focus stacking. See [“Choosing the Number of Shots” \(page 18\)](#).

Focus step width: A value of 5 or less is recommended, as higher settings increase the risk that some areas will be out of focus when the photos are stacked ([page 21](#)). Try experimenting with different settings before shooting.

Interval until next shot: **00** is recommended unless you are using a flash, in which case the interval needs to be long enough for the flash to charge.

Exposure smoothing: **Off** is recommended if lighting and other conditions will not change during shooting, **On** when photographing landscapes and the like under variable lighting.

Silent photography: Choosing **On** (recommended) limits camera shake and reduces power consumption and wear on the shutter. Choose **Off** to prevent flicker when shooting under fluorescent or mercury-vapor lighting (if flicker persists, enable **Flicker reduction** in the photo shooting menu or choose a shutter speed adapted to the frequency of the local power supply: $\frac{1}{125}$ s, $\frac{1}{60}$ s, or $\frac{1}{30}$ s for 60 Hz; $\frac{1}{100}$ s, $\frac{1}{50}$ s, or $\frac{1}{25}$ s for 50 Hz).

Starting storage folder: We recommend that you select both **New folder** and **Reset file numbering**. Each sequence of photos will be numbered from 0001 and stored in its own folder, which you may find helpful when copying the images to a computer.

● Choosing the Number of Shots

The recommended number of shots varies with the lens, aperture, subject size, focus step width, and the distance to the subject, measured from the closest point on the subject to the focal plane mark (\ominus) on the camera body. The figures given on pages [19](#) to [20](#) assume that the camera and subject are positioned as shown below.

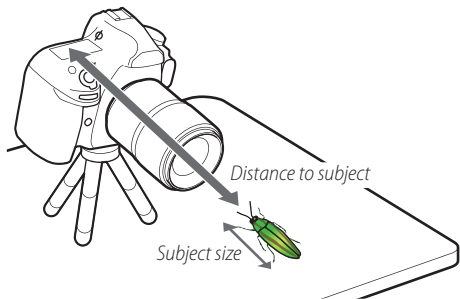

Table 1: AF-S Micro NIKKOR 60mm f/2.8G ED, aperture f/5.6, distance 20 cm (7.9 in.)

		Focus step width									
		1	2	3	4	5	6	7	8	9	10
Subject size (in.)	1	110	110	90	80	50	45	40	30	25	20
	5	—	—	240	200	135	110	90	65	55	45
	10	—	—	300	250	170	140	115	85	65	55
	15	—	—	—	275	185	155	125	90	75	60

For example, around 135 shots would be needed to photograph a 5-inch subject at a focus step width of 5.

Table 2: AF-S Micro NIKKOR 60mm f/2.8G ED, aperture f/8, distance 20 cm (7.9 in.)

		Focus step width									
		1	2	3	4	5	6	7	8	9	10
Subject size (in.)	1	120	80	70	60	40	35	30	20	15	15
	5	—	200	165	140	90	75	65	45	40	35
	10	—	250	210	175	115	95	80	60	45	40
	15	—	275	230	190	125	105	90	65	50	45

Table 3: AF-S VR Micro-Nikkor 105mm f/2.8G IF-ED, aperture f/5.6, distance 35 cm (13.8 in.)

		Focus step width									
		1	2	3	4	5	6	7	8	9	10
Subject size (in.)	1	130	80	70	65	60	55	40	30	25	25
	5	—	220	200	185	150	130	100	85	70	60
	10	—	300	270	255	200	175	135	110	90	80
	15	—	—	—	290	225	195	155	125	100	90

Table 4: AF-S VR Micro-Nikkor 105mm f/2.8G IF-ED, aperture f/8, distance 35 cm (13.8 in.)

		Focus step width									
		1	2	3	4	5	6	7	8	9	10
Subject size (in.)	1	95	70	60	55	45	35	30	25	20	20
	5	250	175	155	140	105	90	75	60	55	45
	10	—	230	205	185	140	120	100	80	70	60
	15	—	260	230	210	160	135	115	90	80	70

● **Focus Shift: Tips**

Although you can reduce the number of shots by increasing the step width, if the step width is greater than the depth of field, you may notice a mix of in- and out-of-focus areas when the photos are stacked.

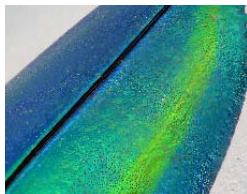

The photos for this stack were shot with a focus step width of 10. A mix of in- and out-of-focus areas is visible on the wings.

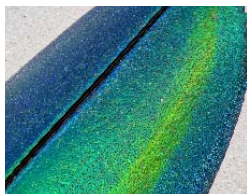

Setting the focus step width to 3 produces a smooth stack with no out-of-focus areas.

Out-of-focus areas will be less obvious at lower resolutions. Check for out-of-focus areas after scaling the image to the desired size.

If the subject moves during shooting (for example, because you are shooting outdoors), focus stacking may not produce the desired results.



Zooming in on the petals reveals that they have been stacked in overlapping positions, giving the effect of a multiple exposure.

- **Before Stacking**

Delete any photos not in the desired focus range before stacking.

● Some Examples of Focus Stacking

Here are some sample images, together with the gear and settings used to create them.



Lens	AF-S Micro NIKKOR 60mm f/2.8G ED		
Distance to subject	20 cm/8 in.	Focus step width	3
Subject size	5 cm/2 in.	Interval until next shot	0
Aperture	f/5.6	Exposure smoothing	On
Shots taken/used*	160/150	Silent photography	On

* The total number of shots taken/the number of shots actually used for focus stacking.

Focus Stacking (Focus Shift Photography)



Lens	AF-S NIKKOR 24–70mm f/2.8E ED VR		
Focal length	70 mm	Focus step width	5
Distance to subject	Approx. 1.5 m/4.9 ft	Interval until next shot	0
Subject size	—	Exposure smoothing	On
Aperture	f/8	Silent photography	On
Shots taken/used	15/10		





Lens	AF-S Micro NIKKOR 60mm f/2.8G ED		
Distance to subject	30 cm/12 in.	Focus step width	3
Subject size	15 cm/6 in.	Interval until next shot	0
Aperture	f/5.6	Exposure smoothing	On
Shots taken/used	250/190	Silent photography	On





White Balance Tips and Tricks

Auto white balance is recommended with most light sources. If the desired results cannot be achieved with auto white balance, choose an option from the list below or use preset white balance.

White Balance Options

Choose from the following options:

Option	K *	Description
AUTO Auto	3500–8000	White balance is adjusted automatically. Suitable for most light sources; if an optional flash unit is used, white balance is adjusted to match. See page 27 for more on AUTO options.
Keep white (reduce warm colors)		
Normal		
Keep warm lighting colors		
 A Natural light auto	4500–8000	White balance is adjusted for natural light, producing colors closer to those seen by the naked eye (page 28).
 Incandescent	3000	Use under incandescent lighting.
 Fluorescent		Use with the light sources below.
Sodium-vapor lamps	2700	• Sodium vapor lighting (found in sports venues)
Warm-white fluorescent	3000	• Warm white fluorescent lights
White fluorescent	3700	• White fluorescent lights
Cool-white fluorescent	4200	• Cool-white fluorescent lights
Day white fluorescent	5000	• Daylight white fluorescent lights
Daylight fluorescent	6500	• Daylight fluorescent lights
High temp. mercury-vapor	7200	• High color temperature light sources (e.g., mercury-vapor lamps)

Option	K*	Description
 Direct sunlight	5200	Use with subjects lit by direct sunlight.
 Flash	5400	Use with optional flash units.
 Cloudy	6000	Use in daylight under overcast skies.
 Shade	8000	Use in daylight with subjects in the shade.
 Choose color temp.	2500–10,000	Choose a color temperature from a list of values.
PRE Preset manual	—	Use your subject or light source or an existing photo as a reference (page 30).

* Color temperature. All values are approximate and do not reflect fine-tuning; colors can be fine-tuned if desired.

● **Auto White Balance for Incandescent Lighting**

AUTO offers a choice of **AUTO₀ Keep white (reduce warm colors)**, **AUTO₁ Normal**, and **AUTO₂ Keep warm lighting colors**. The warm cast of incandescent lighting can be eliminated by selecting **Keep white (reduce warm colors)** or preserved by selecting **Keep warm lighting colors**.

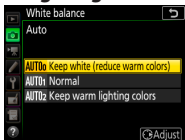

**AUTO₀ Keep white
(reduce warm colors)**



AUTO₁ Normal



AUTO₂ Keep warm lighting colors

● Natural Light Auto

Adapted as it is to natural light sources, **☀️ A Natural light auto** produces better results under natural lighting than comparable auto white balance options. White balance adapts to changes in lighting, producing results close to those seen by the naked eye whether your subject is a sunset or fall colors.

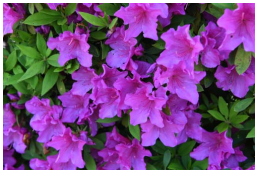

AUTOo Keep white
(reduce warm colors)

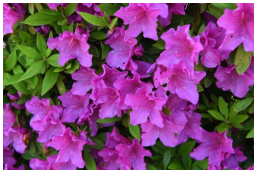

Natural light auto

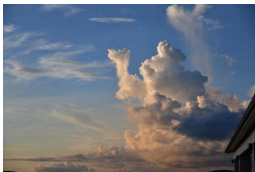

AUTOo Keep white
(reduce warm colors)

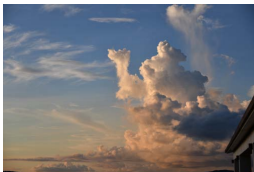

Natural light auto

● Color Temperature Information

The color temperature chosen for auto white balance can be viewed in the playback photo information display. Use this value as a reference when selecting a value for **Choose color temp.**



To view color temperature, go to **Playback display options** in the playback menu and place a check next to **Shooting data**.

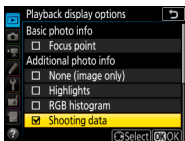

Color temperature and other photo information can then be viewed by pressing  during full-frame playback.



The camera does not display the color temperature for photos with white balance set to **AUTO** and **On (Mode 2)** selected for **Silent live view photography** ([page 46](#)).

● Measuring Preset Manual White Balance

In live view, you can measure white balance from any white or grey object in the frame (spot white balance).

1 Select preset manual white balance.

Press and hold the **WB** button and rotate the main command dial until **PRE** (Preset manual) is displayed in the monitor.



2 Select a preset.

Keeping the **WB** button pressed, rotate the sub-command dial until the desired white balance preset (d-1 to d-6) is displayed.



3 Select direct measurement mode.

Release the **WB** button briefly and then press it again until the **PRE** icon starts to flash. A spot white balance target (□) will be displayed at the selected focus point.



4 Position the target over a white or grey area.

While **PRE** flashes in the display, use the multi selector to position the target over a white or grey area of the frame. To zoom in for more precise positioning, press the  button. You can also measure white balance anywhere in the frame by tapping your subject in the monitor, in which case you can proceed directly to Step 6.



5 Measure white balance.

Press the center of the multi selector or press the shutter-release button all the way down to measure white balance.



6 Exit direct measurement mode.

Press the **WB** button to exit direct measurement mode.

Viewing White Balance Presets

White balance presets d1–d6 can be viewed by selecting **Preset manual** for **White balance** in the photo or movie shooting menu. The white balance target is shown on the preset.



Digitizing 35 mm Film

Digitizing film is a snap with an ES-2 film digitizing adapter. With an ES-2 and a bright light source configured as shown below, you can use the D850's **Negative digitizer** to create positive copies of film negatives.

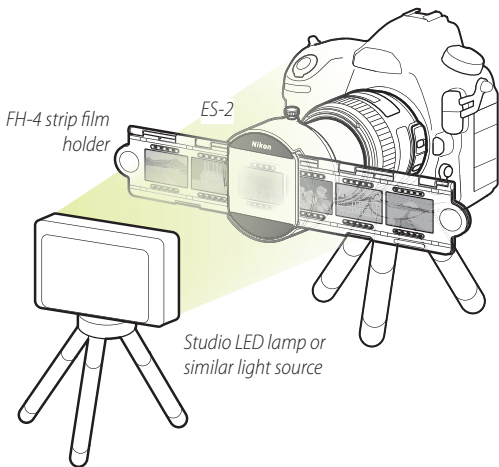

● What You'll Need

Review the required equipment and settings before proceeding.

Required Equipment

Before scanning 35 mm negatives, ready the items below.

- An ES-2 film digitizing adapter, which includes:



ES-2



62 mm adapter **A**



62 mm adapter **B**



FH-4

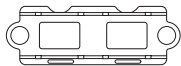

FH-5

- **A compatible lens.** Any of the following can be used:
 - ▶ AF-S DX Micro NIKKOR 40mm f/2.8G
 - ▶ AF-S Micro NIKKOR 60mm f/2.8G ED (requires 62 mm adapter **A**)*
 - ▶ AI AF Micro-Nikkor 60mm f/2.8D (requires 62 mm adapter **B**)*

* Users of this lens can employ an ES-1 slide copy adapter in place of the ES-2 and FH-5 when digitizing slides. A BR-5 ring (available separately) is required when using the ES-1.

Equipment and Settings for Scanning Negative Film



In addition to the ES-2 and one of the lenses listed on [page 33](#), you'll need the following when scanning negatives.

Film	 Color or monochrome negatives
Film holder	FH-4*
Light source	We recommend shooting in a sunny spot by a window or using a photo light box, a studio LED lamp, or a light source with a high R_a (color rendering index)
Technique	Use the Negative digitizer option. The camera functions in mode A (aperture-priority auto).
Focus mode	Manual focus is recommended.
Image quality	Photographs are saved in JPEG format.

* The scannable area is approximately 36 mm × 24 mm. Some portions of the frame cannot be photographed.

Equipment and Settings for Scanning Positive Film

In addition to the ES-2 and one of the lenses listed on [page 33](#), you'll need the following when scanning positives.

	Strip film	Slides
Film	 Positive film	 Mounted positives
Film holder	FH-4 ¹	FH-5 ²
Light source	We recommend shooting in a sunny spot by a window or using a photo light box, a studio LED lamp, or a light source with a high R _a (color rendering index)	
Technique	We recommend shooting in mode A (aperture-priority auto) using live view.	
Focus mode	Manual focus is recommended.	
Image quality	Choose from NEF (RAW), TIFF, and JPEG options.	

1. The scannable area is approximately 36 mm × 24 mm. Some portions of the frame cannot be photographed.
2. The scannable area varies with the dimensions of the mount window. An ES-1 slide copy adapter can be used in place of the ES-2 and FH-5 to digitize mounted positives.

● Handling Film

Wear gloves to keep film free of smudges and fingerprints. Dust and lint can be removed with a blower.



● Digitizing Negatives

The recommended procedure for digitizing negatives using the ES-2 is described below.

1 Ready the equipment.



Set up the equipment as shown on [page 32](#).

2 Start live view.

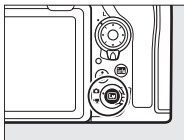
Rotate the live view selector to  (live view photography) and press the  button to start live view.



3 Select Negative digitizer.

Press the  button to display the *i*-button menu, then highlight **Negative digitizer** and press . The colors in the display will be reversed.

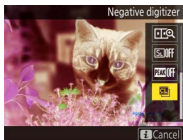

- 4** Choose the film type. Highlight **Color negatives** or **Monochrome negatives** and press **OK**.

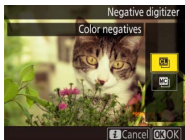

- 5** Frame and focus. Position the FH-4 so that the portion of the frame you wish to digitize is framed in the camera monitor. Additional adjustments can be made by rotating the ES-2 or sliding it in or out while adjusting focus as necessary (manual focus is recommended, as autofocus may fail to produce the desired results depending on the content of the frame). For precise focus, press **Q** to view your subject a higher magnification. After positioning the ES-2 to your satisfaction, tighten the locking screw.

- 6** Adjust exposure. Press **OK** to display brightness adjustment options and press **▲** or **▼** to adjust exposure. Press **OK** to proceed once exposure has been adjusted to your satisfaction.

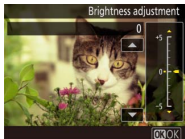

7 Take the photograph.

Press the shutter-release button all the way down to take the photograph and save it in JPEG format.

Using the Negative Digitizer

No options are available for correcting dust, scratches, or uneven colors due to faded film. Photos are saved in JPEG format regardless of the option selected for image quality; photos taken with a JPEG option selected will be saved at the chosen setting, while photos taken with **NEF (RAW)** or **TIFF (RGB)** selected will be saved in JPEG fine★ format. Some menu items and features, including bracketing and focus shift ([page 60](#)), are unavailable, and optional flash units cannot be used.

Pictures are taken in mode **A** regardless of the mode selected before shooting begins; aperture defaults to f/8 but can be adjusted as required. Should you notice flicker when shooting under fluorescent lighting or the like, try stopping aperture down or reducing ISO sensitivity to slow shutter speed to the point that the flicker is eliminated.



● **Digitizing Positives (Slides)**

The recommended procedure for digitizing slides using the ES-2 is described below.

1 Ready the equipment.

Set up the equipment as shown on [page 32](#).

2 Start live view.

Rotate the live view selector to  (live view photography) and press the  button to start live view.

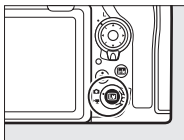

3 Adjust camera settings.

We recommend using the **Flat** Picture Control and shooting in mode **A** at an aperture of around f/8. Should you notice flicker when shooting under fluorescent lighting or the like, try adjusting settings to slow shutter speed to the point that the flicker is eliminated. Matrix metering is recommended, although highlight-weighted metering can be used if you find that highlights are washed out. We also suggest using auto white balance, switching to a setting that matches the light source if auto white balance fails to produce the desired results.

4 **Frame and focus.**

Position the FH-5 so that the portion of the slide you wish to digitize is framed in the camera monitor. Additional adjustments can be made by rotating the ES-2 or sliding it in or out while adjusting focus as necessary (manual focus is recommended, as autofocus may fail to produce the desired results depending on the content of the frame). For precise focus, press  to view your subject a higher magnification. After positioning the ES-2 to your satisfaction, tighten the locking screw.

5 **Take the photograph.**

Press the shutter-release button all the way down to take the photograph and save it at the setting currently selected for image quality.

● Retouching Digitized Photos

Digitized photos can be retouched using Capture NX-D or other image editing software. The principal editing tools in Capture NX-D are outlined below.

Levels & Curves

Adjust contrast, tones, and color balance.

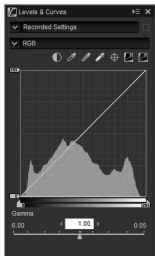

LCH

Adjust lightness, chroma, and hue.

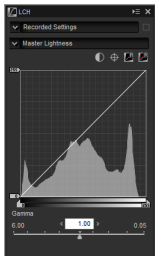

The Straighten Tool

Straighten pictures by up to $\pm 10^\circ$.

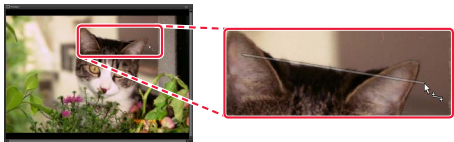

The Crop Tool

Crop unwanted areas from images.

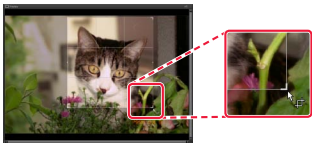

The Auto Retouch Brush Tool

Remove dust and scratches.

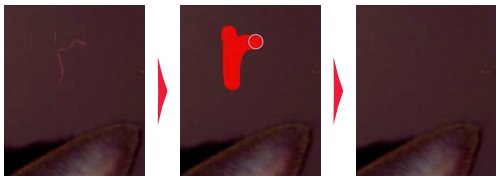

Example

The following example shows how **Levels & Curves** can be used to remove a green cast from an image.

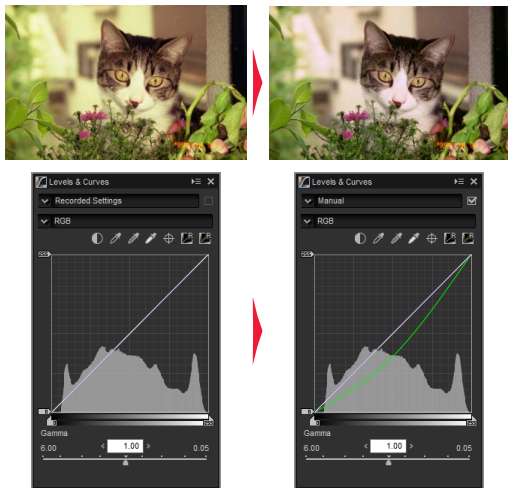

Before using other applications to view images processed using Capture NX-D, save the images in another format using the **Convert Files** option in Capture NX-D.

Muffling the Shutter

Choose quiet or silent photography where camera noise might be a distraction, for example at stage performances, during interviews, or when photographing wildlife.

● “Quiet” Versus “Silent”

The differences between quiet shutter release and silent photography are summarized in the following table.

	Quiet shutter release	Silent photography	
		Mode 1	Mode 2
Framing	Viewfinder	Live view	
Flash	Available	Not available	
Shutter release	Quiet	Silent	
Frame advance rate	Qc: Approx. 3 fps	Cl: 3 fps ¹ Ch: 6 fps	Qc/Cl: 15 fps ² Ch: 30 fps ²
Image area	All	All	DX (24 × 16) ³
Rolling shutter effect?	No	Yes	Some
Suggested for	Ballet, orchestras	Weddings, astronomy, landscapes	Birds, wildlife

1. The maximum frame rate is approximately 3 fps, regardless of option selected for Custom Setting d1 (**CL mode shooting speed**).
2. For up to 3 seconds at a time.
3. Image quality and size fixed at **Normal★**, 3600 × 2400.

● Quiet Shutter-Release Mode

If quiet shutter-release mode is selected for viewfinder photography, the mirror stays up while the shutter-release button is pressed all the way down. The mirror is lowered (more quietly than in single-frame mode) only when the shutter-release button returns to the halfway position, allowing you to control the timing of the click made by the mirror.

To choose quiet shutter-release mode, press the release mode dial lock release and rotate the dial to **Q**. Note that this mode is associated with a certain amount of shutter lag.

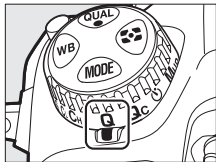

Quiet Continuous Shutter Release

For quiet burst photography with a frame rate of about 3 fps, rotate the release mode dial to **Qc** (quiet continuous).

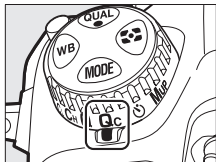

● Silent Photography

In silent photography, the shutter remains open between shots, eliminating shutter noise altogether during live view.

To enable silent photography, press the **i** button during live view and select **On (Mode 1)** or **On (Mode 2)** for **Silent live view photography**.

- **On (Mode 1)**: Reduce vibrations caused by the shutter when shooting landscapes and other static subjects. ISO sensitivity can be set to values of from Lo 1 to 25600.
- **On (Mode 2)**: As for **On (Mode 1)** except that photos can be taken at a higher rate.



When silent photography is in effect, the mirror will only be audible when it is raised and lowered at the start and end of live view. Note that during burst photography, focus and exposure are fixed at the values in effect at the start of each burst.



Camera Sounds

Even when silent photography is in effect, the sound of the camera focusing may still be audible in autofocus mode and the sound of the aperture mechanism will still be audible when you adjust aperture in modes **A** and **M** or the camera adjusts aperture in modes **P** and **S**.

● Movie Stills



Another way to reduce camera noise is to film movies silently and later make JPEG stills using **Save current frame**.

1 Pause playback on the desired frame.

Press  to pause playback and then press  or  to display the desired frame.



2 Choose **Save current frame**.

Press  or , then highlight **Save current frame** and press  to create a JPEG copy of the current frame.

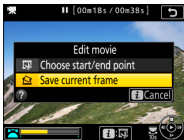

Save Current Frame

Movie stills are recorded at the dimensions selected for **Frame size/frame rate** in the movie shooting menu. If two memory cards are inserted, the still will be saved to the card chosen using **Primary slot selection** in the photo shooting menu.

JPEG movie stills created with the **Save current frame** option cannot be retouched and lack some categories of photo information.

Focus Peaking

In manual focus mode, the **Peaking level** item in the **i**-button menu can be used to enable focus peaking, which employs colored outlines to indicate objects that are in focus.

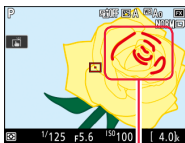

Area in focus

The options in the **Peaking level** menu are **3** (high sensitivity), **2** (standard), **1** (low sensitivity), and **Off**; the higher the setting, the greater the depth shown as being in focus.

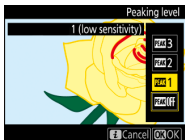

Focus Peaking

Peaking remains in effect during focus zoom. The color can be selected using Custom Setting d8 (**Peaking highlight color**). Choose from **Red**, **Yellow**, **Blue**, and **White**.

Cropping and Zoom

Quick crop can be used during playback to save the crop currently visible in the monitor, creating a copy with an aspect ratio of 4:3. Use it for quick “what-you-see-is-what-you-get” cropping (for other aspect ratios, use the **Trim** option in the retouch menu).

1 Zoom in.

Press the  button to zoom in on the image currently displayed in full-frame playback. Note that **Quick crop** is not available when an RGB histogram is displayed.

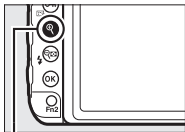

 button

2 Choose a crop.

Use the multi selector to scroll the image until the desired area is displayed in the monitor.



3 Press the *i* button.

Press the *i* button to display the *i*-button menu.

4 Select **Quick crop**.

Highlight **Quick crop** and press  to save the cropped copy. JPEG images are saved in the same format as the original, while copies created from NEF (RAW) and TIFF images are saved in JPEG fine★ format.

On-Camera Batch NEF (RAW) Processing

JPEG copies can be created from NEF (RAW) images using the **NEF (RAW) processing** option in the camera retouch menu.

● **The Benefits of On-Camera Processing**

On-camera batch NEF (RAW) processing lets you apply identical settings to multiple images in a single pass; for greater efficiency, you can even select images by date. Processing images on the camera is much faster than on a computer, as can be seen from the following comparison of the times needed to process 500 NEF (RAW) images shot at a bit depth of 14 bits using lossless compression.

- **Computer:** *approximately 97 minutes* (Windows 10, 3.3 GHz Core i7-6567U processor, 16 GB RAM, batch processing performed using Capture NX-D version 1.4.6)
- **Camera:** *approximately 17 minutes* (images read from a 256 GB SONY G-series XQD card and written to a 256 GB Lexar Professional 1000× UHS-II SDHC/SDXC card)

● On-Camera NEF (RAW) Processing

Follow the steps below to create JPEG copies of NEF (RAW) images using the camera NEF (RAW) processing option.

1 Select NEF (RAW) processing.

Highlight **NEF (RAW) processing** in the retouch menu and press .

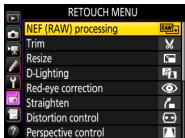

2 Choose a destination.

If two memory cards are inserted, the NEF (RAW) images can be read from one card and the JPEG copies saved to the other, further reducing processing time (if only one memory card is inserted, proceed to Step 3).

To choose the destination for the JPEG copies, highlight **Choose destination** and press .

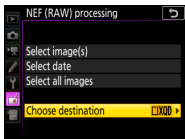

Highlight a card slot and press  when prompted.

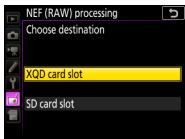

3 Choose how images are selected.

Choose from the options below.

- **Select image(s):** Select images manually (proceed to Step 5). Use this option to process a single image or to select multiple images for batch processing.
- **Select date:** Create JPEG copies of all the NEF (RAW) images taken on selected dates (proceed to Step 4).
- **Select all images:** Create JPEG copies of all the NEF (RAW) images on the memory card (proceed to Step 4).

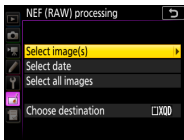

4 Select the source slot.

If two memory cards are inserted, you will be prompted to select the slot with the card containing the NEF (RAW) images. Highlight the desired slot and press . If you chose **Select all images** in Step 3, proceed to Step 6.

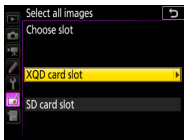

5 Select photographs.

If you chose Select image(s) in Step 3, a picture selection dialog will be displayed. Highlight images using the multi selector and press the center of the multi selector to select or deselect; selected images are indicated by a ✓ icon. To view the highlighted image full screen, press and hold the Ⓜ button. Press Ⓞ to proceed to Step 6 when your selection is complete; all selected images will be processed at the same settings.



If you chose Select date in Step 3, a list of dates will be displayed. Highlight dates using the multi selector and press Ⓜ to select or deselect. Press Ⓞ to select all NEF (RAW) pictures taken on the chosen dates and proceed to Step 6; all selected images will be processed at the same settings.

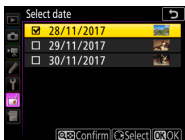

6 Choose settings for the JPEG copies.

Adjust the settings listed below.



- 1 Image quality
- 2 Image size
- 3 White balance
- 4 Exposure compensation
- 5 Picture Control



- 6 High ISO NR
- 7 Color space
- 8 Vignette control
- 9 Active D-Lighting

7 Copy the photographs.

Highlight **EXE** and press **OK** to create the JPEG copies (if multiple photos are selected, a confirmation dialog will be displayed; highlight **Yes** and press **OK**). To exit without copying the photographs, press the **MENU** button.



NEF (RAW) Processing

NEF (RAW) processing is available only with NEF (RAW) images created with D850 cameras. Photos in other formats or shot with other cameras will not be listed in the photo selection dialog in Step 5. In addition, white balance and vignette control cannot be applied to multiple exposures or pictures created with image overlay.

Exposure compensation for NEF (RAW) processing can only be set to values between -2 and $+2$ EV.

Auto AF Fine-Tuning

The D850 can fine-tune autofocus automatically. The results can be used with all lenses of the same type.



Use only as required. AF fine-tuning should be performed at the focus distance at which the lens is normally used; fine-tuning performed at short focus distances may be less effective with distant subjects and vice versa.

1 Ready the camera.

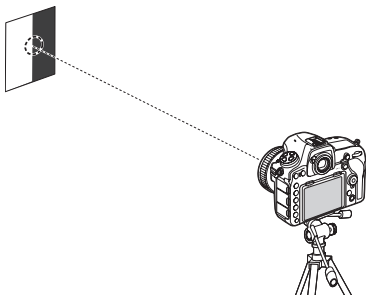
Mount the camera on a tripod and aim the camera at a flat, high-contrast subject parallel to the camera focal plane. Note that auto AF fine-tuning works best at maximum aperture and may not function in dark surroundings.



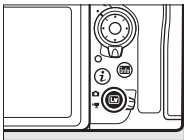

2 Start live view.

Rotate the live view selector to  and press the  button.

**3 Adjust focus settings.**

Rotate the focus-mode selector to AF and use the AF-mode button and command dials to select the following:

- **Autofocus mode:** AF-S
- **AF-area mode:**  (wide),  (normal), or  (pinpoint)

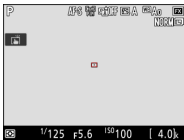
**4 Select the center focus point.**

Press the center of the multi selector to select the center focus point.

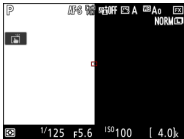
**5 Focus.**

Press the shutter-release button halfway to focus, then zoom in on the view through the lens to confirm that the subject is in focus. Focus can be adjusted manually if necessary.

6 Perform auto AF fine-tuning.

Press the AF-mode and movie-record buttons simultaneously and keep them pressed until the dialog shown in Step 7 is displayed (this should take slightly over two seconds).

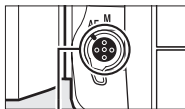

AF-mode button

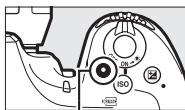

Movie-record button

7 Save the new value.

Highlight **Yes** and press **OK** to add the AF fine-tuning value for the current lens to the saved values list (CPU lenses only). Note that only one value can be stored for each type of lens.

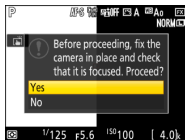
**8** Enable AF fine-tuning.

In the camera setup menu, select **AF fine-tune** > **AF fine-tune (On/Off)**, then highlight **On** and press **OK**.

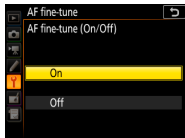

Unavailable Menu Options

If you find that the menu items mentioned in this manual are grayed out, you may be able to access them by changing camera settings as described below.

● The Photo Shooting Menu

White balance (page 30)

"Preset manual" > "Copy from existing photograph" unavailable

- Check that a memory card is selected as the destination and that it is inserted, formatted, undamaged, and contains at least one photo.
- Ensure the selected preset is not protected.
- Wait for recording (including multiple exposure photography) to end.

Focus shift shooting (page 8)

"Focus shift shooting" unavailable

- Use an AF-S or AF-P lens.
- Rotate the focus-mode selector to **AF**.
- End multiple exposure, interval timer, bracketing, HDR, negative digitizer, and time-lapse recording.
- Set the camera clock.
- Exit image transfer mode.

"Focus shift shooting" > "Start" unavailable

- If **Record movies** is selected for Custom Setting g1 (**Custom control assignment**) > **Shutter release button**, rotate the live view selector to .
- End self-timer photography.

● **The *i*-Button Menu (Live View Photography)**

Negative digitizer ([page 32](#))

“Negative digitizer” unavailable

- End bracketing, HDR, and silent (mode 2) photography.
- Exit image transfer mode.
- End the connection to the SnapBridge app.