



# NIKKOR

## **NIKKOR Z 600mm f/4 TC VR S**

### Repair Manual

# Table of Contents

<b>Introduction</b>	<b>1</b>
Important Information .....	1
Notations used in this Repair Manual .....	2
Safety precautions .....	4
Disclaimer of warranties and limitation of damages .....	6
Notification .....	6
<b>Service tools</b>	<b>7</b>
Nikon service tools .....	7
Standard service tools .....	7
<b>Illustrated Service Parts List</b>	<b>8</b>
<b>Parts Removal and Replacement Procedures</b>	<b>12</b>
Before disassembling the Product .....	12
During the repairing .....	12
Disassembly .....	13
TRIPOD BASE .....	13
NAME PLATE .....	14
FILTER HOLDER UNIT .....	14
SW UNIT .....	15
TC LEVER .....	15
TC COVER UNIT .....	16
BUTTON HOLDING PLATE .....	16
TRIPOD RETAINER RING .....	17
TRIPOD RING UNIT .....	17
REAR COVER RING UNIT .....	19
MOUNT .....	20
FILTER FRAME .....	20
REAR TUBE UNIT .....	21
CONTACT UNIT .....	21
MF RING UNIT .....	22
TC DRIVING UNIT .....	22
FN RUBBER RING .....	23
GRIP RUBBER RING .....	24
FRONT RUBBER .....	24
HOOD MOUNTING RING .....	25

Assembly .....	26
HOOD MOUNTING RING .....	26
FRONT RUBBER.....	27
GRIP RUBBER RING .....	27
FN RUBBER RING .....	28
TC DRIVING UNIT .....	28
MF RING UNIT.....	29
CONTACT UNIT.....	30
REAR TUBE UNIT .....	32
FILTER FRAME .....	33
MOUNT .....	34
REAR COVER RING UNIT.....	35
TRIPOD RING UNIT .....	35
TRIPOD RETAINER RING .....	38
BUTTON HOLDING PLATE .....	38
TC COVER UNIT .....	39
TC LEVER.....	39
SW UNIT .....	40
FILTER HOLDER UNIT.....	40
NAME PLATE .....	41
TRIPOD BASE.....	41

---

**AF Accuracy Inspection Process 43**

AF accuracy inspection .....	45
------------------------------	----

---

**Control Ring Inspection Process 47**

Control ring inspection.....	47
------------------------------	----

---

**MF Ring Inspection Process 49**

MF ring inspection .....	49
--------------------------	----



# Introduction

## Important Information

- For purposes of this Repair Manual, "Nikon" means Nikon Corporation, and all direct and indirect affiliated companies, including without limitation, Nikon Inc.
- This Repair Manual is solely intended for Nikon products imported into and sold in the United States by Nikon Inc.
- This Repair Manual includes technical instructions for replacing Nikon parts for the above-mentioned product (the "Product") and is intended for individuals with the knowledge, experience, and tools required to repair electronic devices. Read this entire Repair Manual first. If you are not comfortable performing the repairs as instructed in this Repair Manual, do not proceed.
- Please note that, if you repair the Product on your own, we will not provide customer support or assistance regarding this Repair Manual or how to repair the Product. Please note that an incorrect repair may affect the Product's limited warranty and/or cause an increase in the fee if you request service from an authorized Nikon service center if you have repaired the Product on your own. This Repair Manual is subject to revision without notice.
- Failure to follow the repair instructions or to use appropriate Nikon parts or tools may cause fire or other safety issues and lead to personal injury or death. Failure to follow the repair instructions or to use appropriate parts or tools may damage the Product or other property, or compromise the Product's functionality or water resistance (if applicable).
- NIKON SHALL NOT BE LIABLE FOR ANY DAMAGES, INJURIES OR OTHER LIABILITIES TO THE PRODUCT, OR ANY PERSON, OR PROPERTY WHICH OCCURS AS A RESULT OF REPAIR, DIAGNOSIS, MAINTENANCE, OR MODIFICATION PERFORMED BY YOU OR AN UNAUTHORIZED REPAIR PROVIDER, INCLUDING BUT NOT LIMITED TO, ANY INDIRECT, INCIDENTAL, SPECIAL OR CONSEQUENTIAL DAMAGES; ANY LOSS OF DATA, PRIVACY OR PROFITS; OR ANY INABILITY TO USE, OR REDUCED FUNCTIONALITY OF, THE PRODUCT.

# Notations used in this Repair Manual

In this guide, important information is indicated by the following icons.

 <b>WARNING</b>	This indicates that improper use by ignoring the contents described herein can result in potential death or serious injury.
 <b>CAUTION</b>	This indicates that improper use by ignoring the contents described herein can result in potential injury or material loss.
<b>IMPORTANT</b>	This symbol indicates important information in this manual.

## Product identification information

The NIKKOR Z 600mm f/4 TC VR S serial number is written on NAME PLATE as illustrated below.

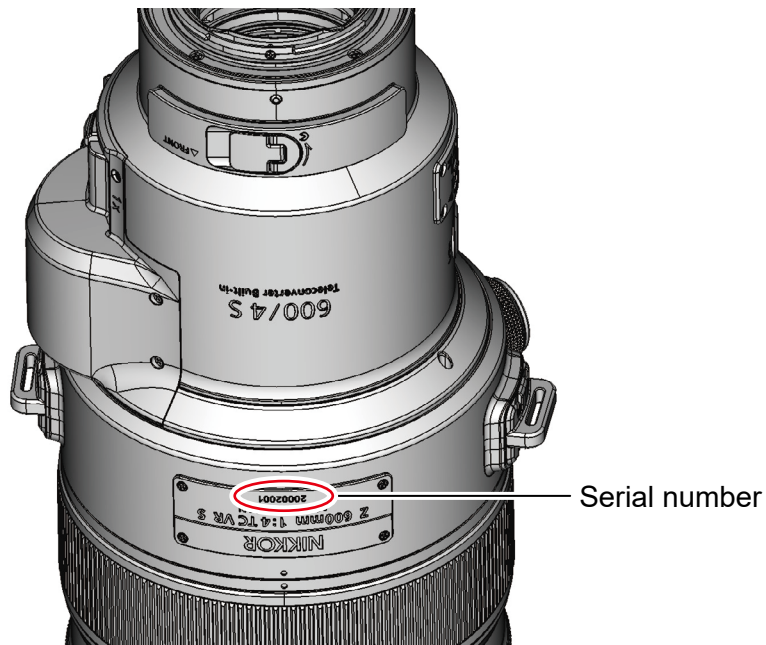

### **CAUTION**

- The serial number may be required when you contact Nikon with regards to the Product. Make sure not to lose the serial numbered part of the Product.

## **Read this first**

- No part of this Repair Manual may be reproduced, transmitted, transcribed, stored in a retrieval system, or translated into any language in any form, by any means, without Nikon's prior written permission.
- Illustrations shown in this Repair Manual may differ from the actual Product.
- Nikon is not responsible for any errors this Repair Manual may contain.
- The appearance, specifications, and capabilities of this Product and parts are subject to change without notice.

## **About controls for radio interference**

- This device complies with Part 15 of the FCC Rules. Operation is subject to the following two conditions:
  - (1) This device may not cause harmful interference, and
  - (2) This device must accept any interference received, including interference that may cause undesired operation.
- This equipment has been tested and found to comply with the limits for a Class B digital device, pursuant to Part 15 of the FCC Rules and to EU EMC directive. These limits are designed to provide reasonable protection against harmful interference in a residential installation. This equipment generates, uses and can radiate radio frequency energy and, if not installed and used in accordance with the instructions, may cause harmful interference to radio communications. However, there is no guarantee that interference will not occur in a particular installation. If this equipment does cause harmful interference to radio or television reception, which can be determined by turning the equipment off and on, the user is encouraged to try to correct the interference by one or more of the following measures:
  - Reorient or relocate the receiving antenna.
  - Increase the separation between the equipment and receiver.
  - Consult the dealer or an experienced radio/TV technician for help.

# Safety precautions

Strictly observe the guidelines contained in this Repair Manual in order to use this Product safely and prevent possible injury or property damage to you and others. Understand the contents thoroughly for correct use of the Product.

## General safety precautions

Always observe the following general safety precautions.

- If you disassemble or repair the Product, it may involve risks of electric shock, Product damage, fire, and/or personal injury, or other hazards. Be careful when disassembling or repairing the Product as described in this Repair Manual.
- If you disassemble or repair the Product, the flange back or the back focus may shift, which may affect the focus when shooting. Check the focus position before disassembling or repairing the Product. Then, ensure that the focus position has not changed after re-assembling the Product. If the focus changes after re-assembling the Product, we recommend that you disassemble and repair the Product again.
- If the Product is dropped or has been subjected to an impact due to dropping, or weight or stress has been placed on it, the camera and lens attachment parts may become deformed, which will prevent the Product from being able to be attached and will cause problems when shooting. In such cases, accurate adjustments and repair will be required and it is recommended that you contact Nikon for service repairs.
- If the Product contains a lithium-ion battery, then inappropriate use, transportation, recycling, re-use, or disposal of the lithium-ion battery may cause a fire, explosion or other damage or injury. Lithium-ion batteries should be handled in accordance with local laws, rules, and regulations. Do not heat, create holes in, disassemble, or incinerate the Product or the lithium-ion battery. Do not leave the Product or the lithium-ion battery in direct sunlight or other hot places for long periods of time, and do not charge the Product in such an environment as doing so may damage the lithium-ion battery or cause it to melt, which may cause a fire, explosion or other damage or injury.
- Do not dispose of your old Product or its lithium-ion battery (if any) and the replaced parts in your household trash or recycling bin. When disposing of the lithium-ion battery, follow your local area laws, rules, and regulations.

## **Repair-specific precautions and warnings**

- As for the Product powered on by the power switch, before disassembling the Product, ensure that the Product is powered off and that the battery has been removed.
- As a safety measure, we recommend that you wear protective eyewear when disassembling or reassembling the Product.
- Always check the following points before and while disassembling the Product.
  - Wear an anti-static wrist strap.
  - The work area is appropriately grounded, and an environment in which electrostatic discharge (ESD) has been provided with safety measures is ensured.
- Before starting work, check that you are following the general guidelines and ESD compliance steps. For details, refer to "Before disassembling the Product" on page 12.
- When removing any parts from the Product, place all the attached parts and screws away from the work area to prevent the Product and parts from being damaged or lost.

## **Safety policy and procedure**

- All Product safety issues must be managed according to the following points.

If any of the following conditions are visible, stop repairing the Product and contact Nikon's customer service at [www.nikonproductsupport.com](http://www.nikonproductsupport.com).

  - There are burnt or melted components or traces on the outside of the Product, or other heat-related damage (including scorching on charging terminals or other connection terminals).
  - The Product has burnt or melted parts or traces on the inside, or contains damage from overheating.
  - Products that appear to have problems such as having been forcibly detached or disassembled for reasons other than misuse by the user or unauthorized repair (those that have been damaged by being subjected to an impact due to dropping, those that have evidence of tampering, or those with damage or separation caused by dilatation of the battery).
  - Plastic parts with sharp edges that may pose an injury risk to the user.
- When contacting Nikon's customer service, please have the following information ready to enable us to check the situation:
  - Model, model number, and serial number of the affected Nikon Product and any third-party product used together with the Nikon Product, if any.
  - Description of the damage found.
  - Clear photos that show the damage.

## Disclaimer of warranties and limitation of damages

- All the information, descriptions, materials, and products provided on or in connection with this Repair Manual are provided by Nikon on an "as-is basis" and "the form that can only be provided if possible" unless otherwise expressly specified in writing by Nikon. With respect to the information, descriptions, materials, and products included in this Repair Manual, that accompany this Repair Manual, or that are provided to users in some way, Nikon makes no, and hereby disclaims all, representations, unless expressly specified in writing. You hereby expressly agree that your use of the information, descriptions, materials, and products included in this Repair Manual or that accompany this Repair Manual are the user's sole responsibility. If you are not in agreement with the foregoing, do not use this Repair Manual.
- To the maximum extent allowed by applicable law, Nikon disclaims all warranties, express or implied. This includes the implied warranties of the merchantability and fitness for a particular purpose, but shall not be limited to these. To the maximum extent allowed by applicable law, Nikon disclaims and shall not be responsible for any damage that may arise through the use of any information, descriptions, materials, or products obtained from this Repair Manual or in connection with this Repair Manual. This includes direct, indirect, incidental, special, consequential, and/or punitive damages, but shall not be limited to these.

SOME STATES DO NOT ALLOW (A) LIMITATIONS ON HOW LONG AN IMPLIED WARRANTY LASTS OR (B) THE EXCLUSION OR LIMITATION OF INCIDENTAL OR CONSEQUENTIAL DAMAGES, SO THE ABOVE LIMITATIONS OR EXCLUSIONS MAY NOT APPLY TO YOU.

## Notification

- Nikon and its suppliers may have patents, patent applications, trademarks, copyrights, and/or other intellectual property and/or proprietary rights regarding the subject matter in this Repair Manual (collectively, "Intellectual Property Rights"). By making this Repair Manual available to you, Nikon does not grant any Intellectual Property Rights and does not imply a license. When the user uses the Intellectual Property Rights with permission, it is only subject to Nikon's and its suppliers' Intellectual Property Rights.

This Repair Manual and the information contained herein are subject to change without notice.

©2024 Nikon Corporation. All rights reserved.

# Service tools

This section shows the tools used to repair products. The standard service tools are commercially available and can be purchased from third party retailers. Nikon hereby disclaims all responsibility and liability for any tools or other items purchased from third party retailers.

## Nikon service tools

- Cleaning stick (EIZ0163)
- Lubricant (PL-1016EL)
- Lubricant (LEN317A)
- Lubricant (FG-600T)
- Lubricant (OS-30MHP)
- Lubricant (MDF-400T)
- Lubricant (G-03031X)
- Lubricant (DT-C4A)

## Standard service tools

- Electrostatic discharge (ESD) mat
- Anti-ESD wrist strap (1 M $\Omega$  resistance)
- Anti-ESD gloves
- Protective eyewear
- Isopropyl alcohol
- Isopropyl alcohol dispenser bottle
- Anti-ESD tweezers
- Phillips screwdriver (2.0 mm)
- Torque screwdriver (Use a product with a torque range of 0.1 N·m to 0.2 N·m.)
- Brush for lubricant
- Rear cap (LF-N1)
- Glue (LOCTITE 241)
- Glue (ThreeBond 1401C)
- Glue (SX720B)
- Soldering iron
- Solder
- Spanner (3.6 mm wide)

# Illustrated Service Parts List

## IMPORTANT

- If you need the parts marked in gray in the illustration, please contact Nikon's customer service at [www.nikonproductsupport.com](http://www.nikonproductsupport.com).
- When disassembling and reassembling the Product, be careful not to damage or lose the parts.

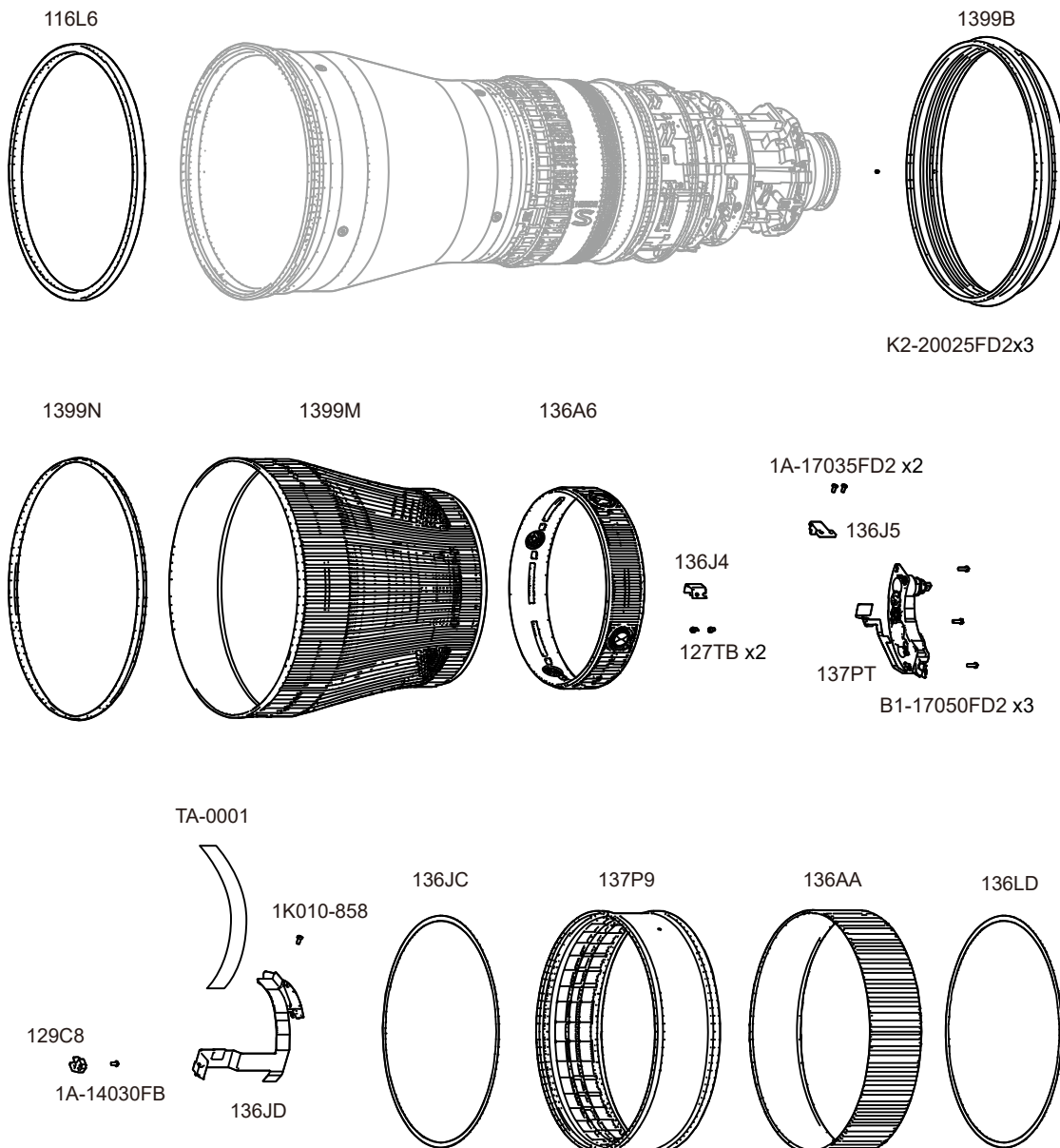

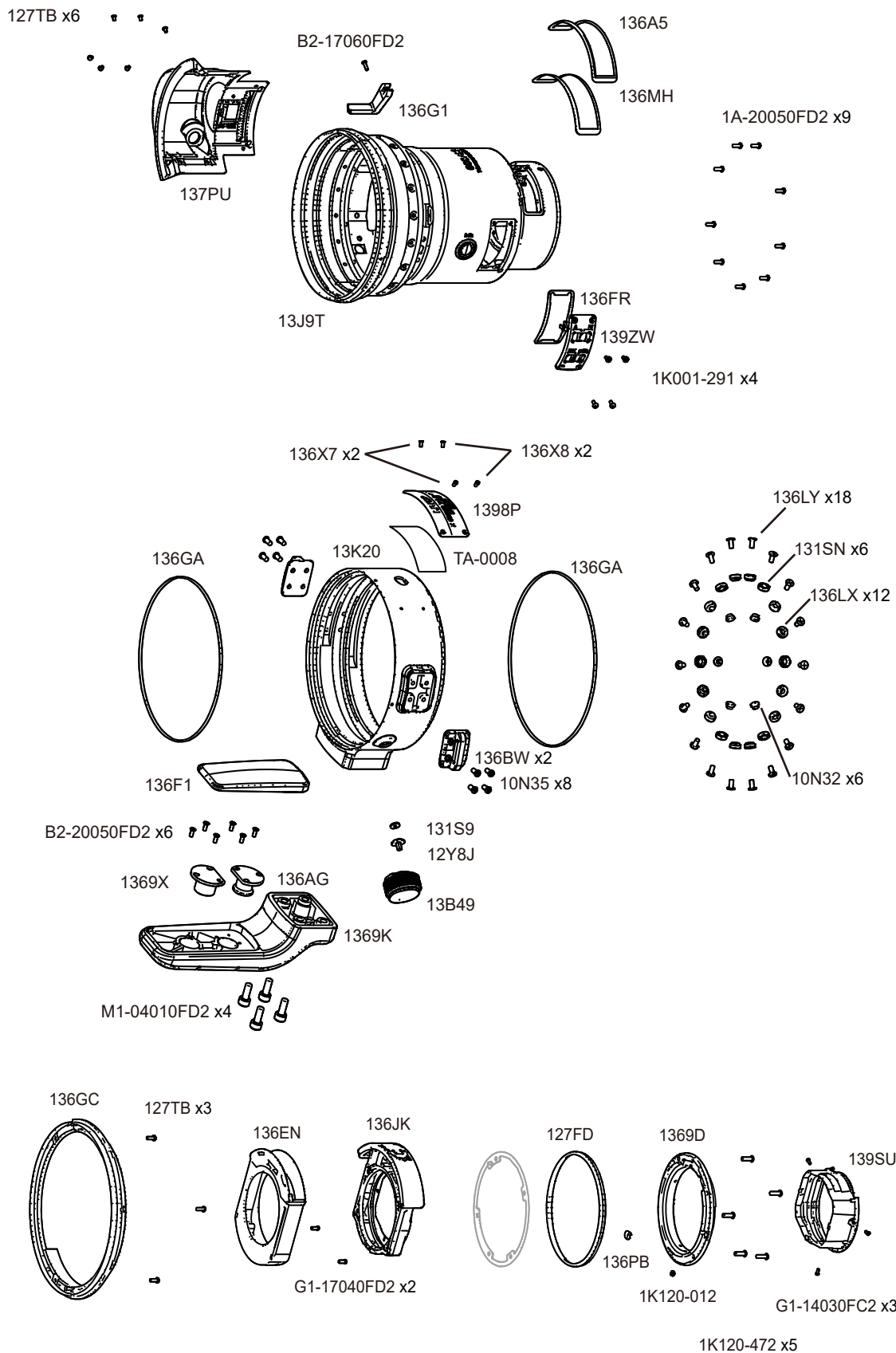

The parts highlighted in purple are not included with the LENS UNIT.

### LENS UNIT

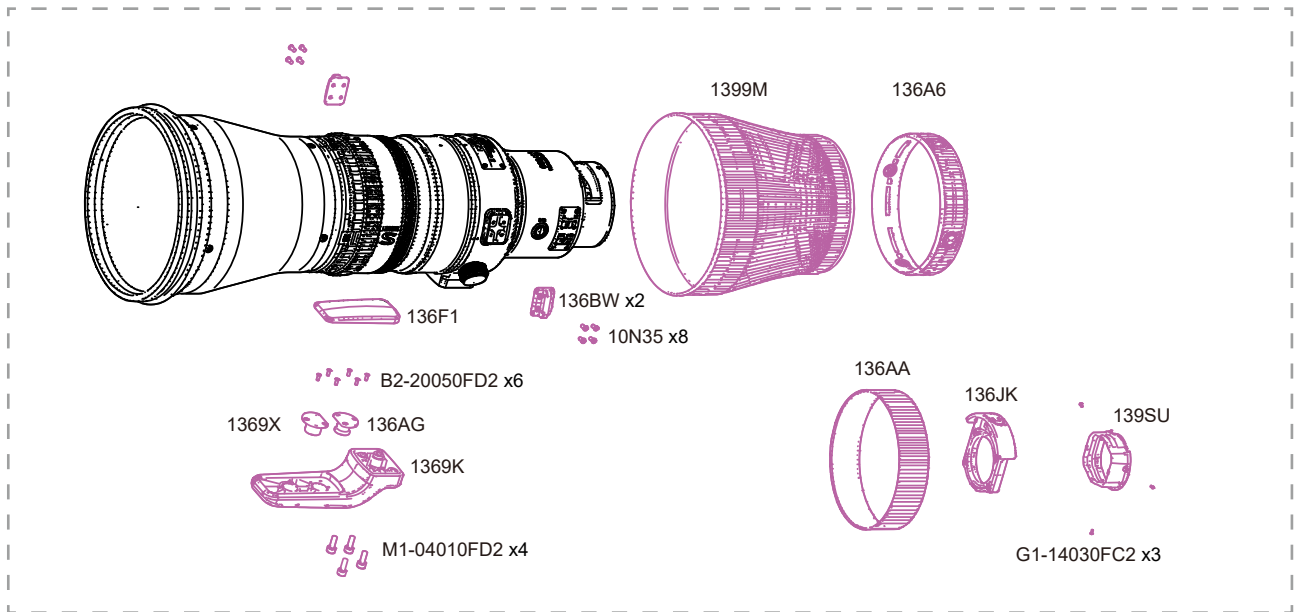

Item code	Parts name	Q'ty
116L6	FRONT RUBBER	1
K2-20025FD2	SCREW	3
1399B	HOOD MOUNTING RING	1
1399N	GOLD RING	1
1399M	GRIP RUBBER RING	1
136A6	FN RUBBER RING	1
127TB	SCREW	11
136J4	BUTTON HOLDER PLATE	1
1A-17035FD2	SCREW	2
136J5	TC STOPPER PLAT	1
137PT	TC DRIVING UNIT	1
B1-17050FD2	SCREW	3
129C8	TC DETECTION UNIT	1
1A-14030FB	SCREW	1
TA-0001	TAPE	1
136JD	CONTACT UNIT	1
1K010-858	SCREW	1
136JC	WASHER	1
137P9	MF RING UNIT	1
136AA	MF RUBBER RING	1
136LD	WASHER	0 to 1
136LE	WASHER	0 to 1
136LF	WASHER	0 to 1
136LG	WASHER	0 to 1
136LH	WASHER	0 to 1
136LJ	WASHER	0 to 1
136LK	WASHER	0 to 1
137PU	TC COVER UNIT	1
B2-17060FD2	SCREW	1
136G1	TC LEVER	1
13J9T	REAR TUBE UNIT	1
136A5	FILTER RUBBER	1
136MH	DOUBLE STICK TAPE	1
136FR	RUBBER	1
139ZW	SW UNIT	1
1K001-291	SCREW	4
1A-20050FD2	SCREW	9
136GA	WASHER	2
13K20	TRIPOD ATTACHING RING UNIT	1
136F1	TRIPOD BASE RUBBER	1
B2-20050FD2	SCREW	6
1369X	TRIPOD SCREW(L)	1
136AG	TRIPOD SCREW(S)	1
1369K	TRIPOD BASE	1
M1-04010FD2	SCREW	4
10N35	SCREW	8
136BW	EYELET RING	2
131S9	PIN	1
12Y8J	SCREW	1
13B49	TRIPOD KNOB UNIT	1
136X7	SCREW	2
1398P	NAME PLATE	1
136X8	SCREW	2
TA-0008	TAPE	1
136LY	SCREW	18
131SN	ROLLER	6
136LX	ROLLER	12
10N32	ROLLER SHAFT	6
136GC	RETAINING RING	1
136EN	FILTER FRAME	1
G1-17040FD2	SCREW	2
136JK	FILTER HOLDER UNIT	1
127FD	RUBBER	1
136PB	POSITIONING PLATE	1
1369D	MOUNT	1
1K120-012	SCREW	1
1K120-472	SCREW	5
139SU	REAR COVER RING	1
G1-14030FC2	SCREW	3
※	LENS UNIT	1

※To place an order for this part, please contact Nikon's customer service at [www.nikonproductsupport.com](http://www.nikonproductsupport.com) with the item code and part name (as applicable).

# Parts Removal and Replacement Procedures

## Before disassembling the Product

### IMPORTANT

- As for the Product powered on by the power switch, before disassembling the Product, be sure to check that the Product is powered off and that the battery has been removed.
- Check that all the lenses, camera, and accessories attached to the Product are removed before disassembling the Product.
- Always cover the workbench's surface with a soft, non-scratch material suitable for ESD protection.
- Frequently clean the surfaces you use to work and keep them free of debris/abrasive particles.
- Always follow the work steps described in each process section.

## During the repairing

### IMPORTANT

- If there is this kind of indication, apply the specified grease or adhesive by a small brush.  
Example: **MDF-1173S**, **AX-125**
- If there is a specified torque, use an appropriate torque driver for tightening screw.  
Example: 0.1 N·m
- If the parts are associated with circled numbers, please work in that numerical order.  
Example: ① ② ③ means to work in the order of ① to ③.
- Do not pinch FPCs or cords during reassembly.
- Be careful not to damage or lose parts.

# Disassembly

TRIPOD BASE

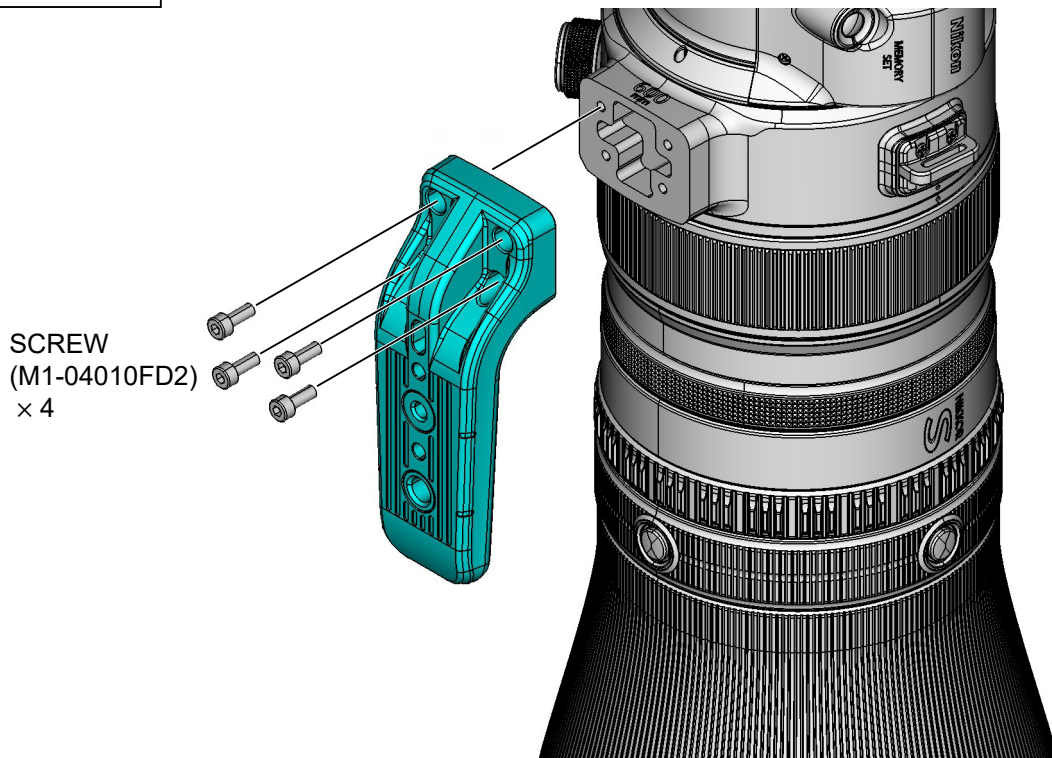

TRIPOD BASE RUBBER  
(136F1)

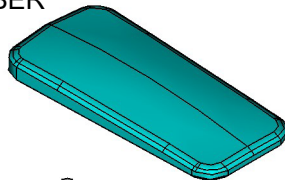

TRIPOD SCREW (S)  
(136AG)

SCREW  
(B2-20050FD2)  
× 6

TRIPOD SCREW (L)  
(1369X)

TRIPOD BASE  
(1369K)

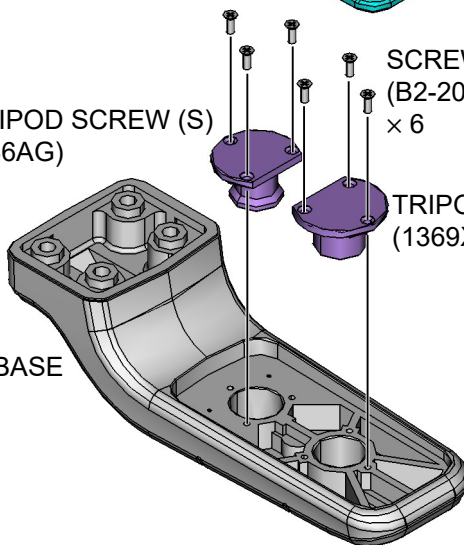

NAME PLATE

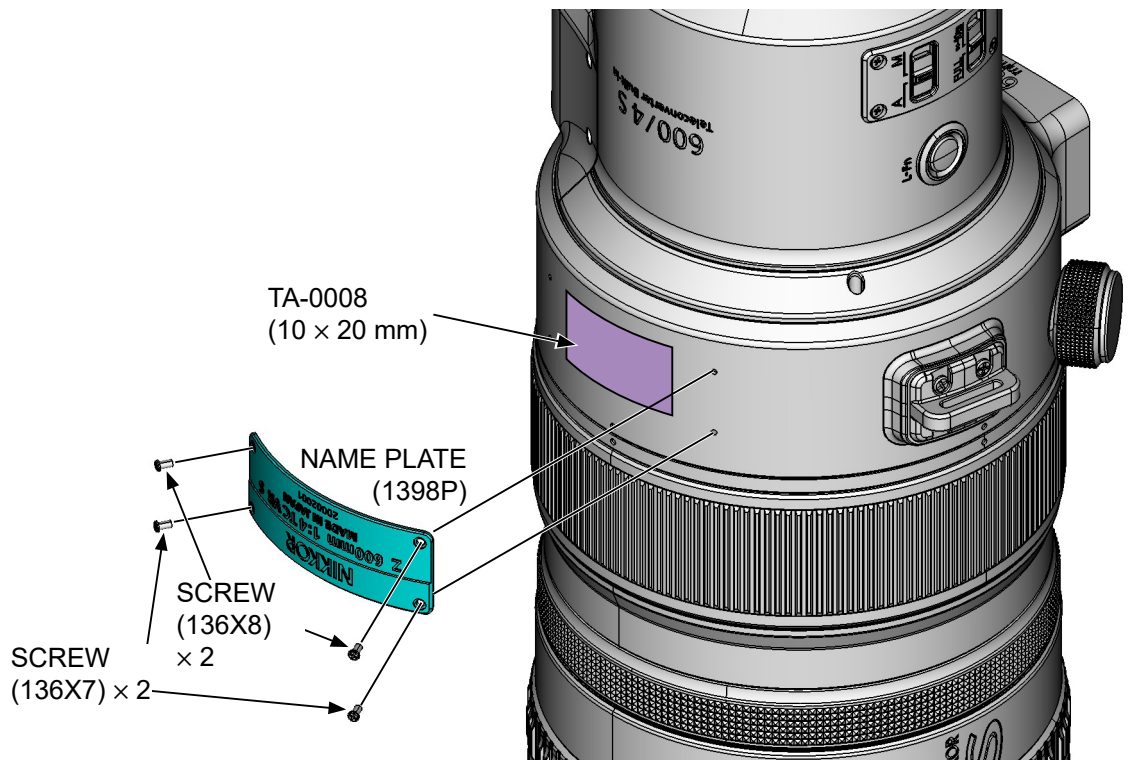

FILTER HOLDER UNIT

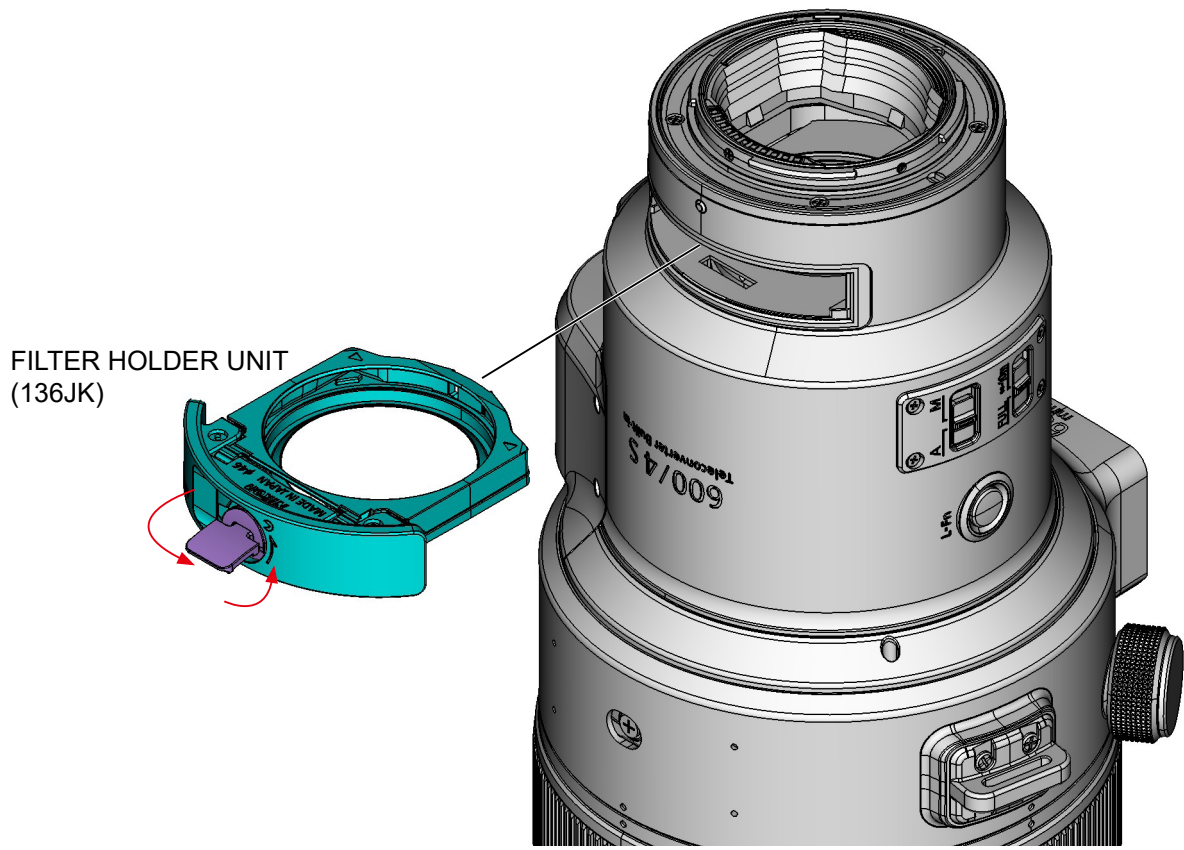

SW UNIT

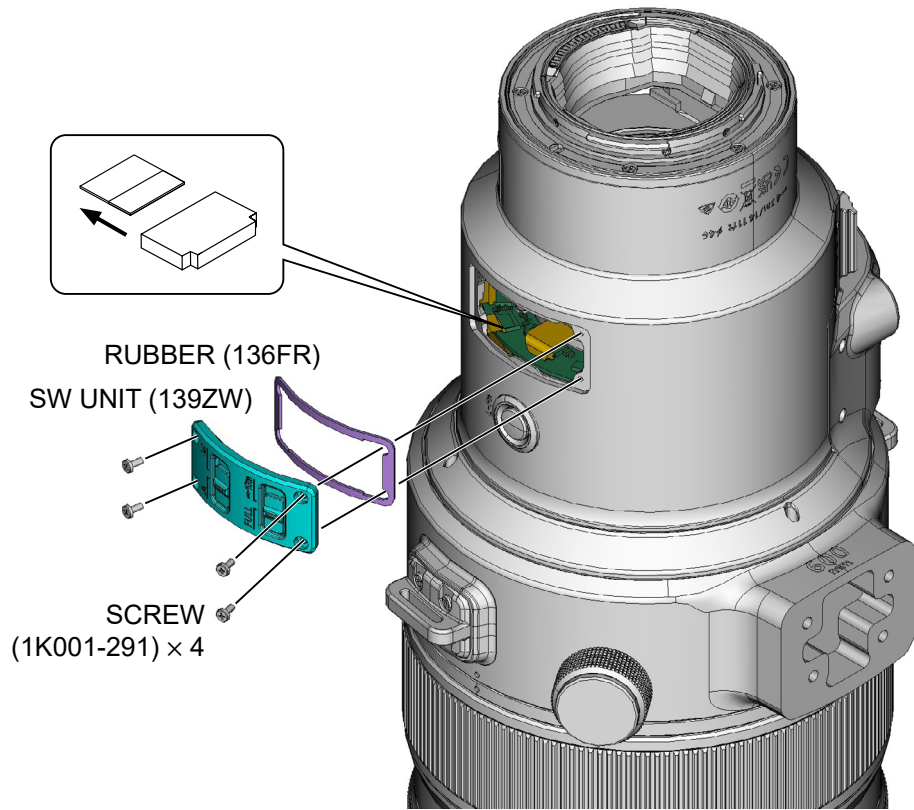

TC LEVER

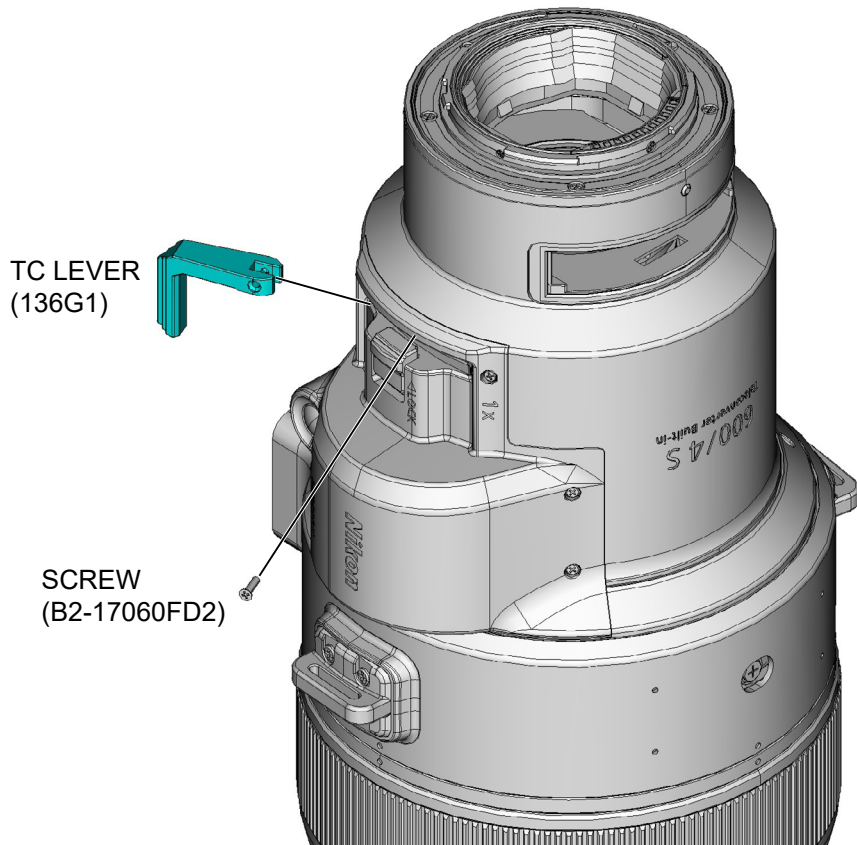

TC COVER UNIT

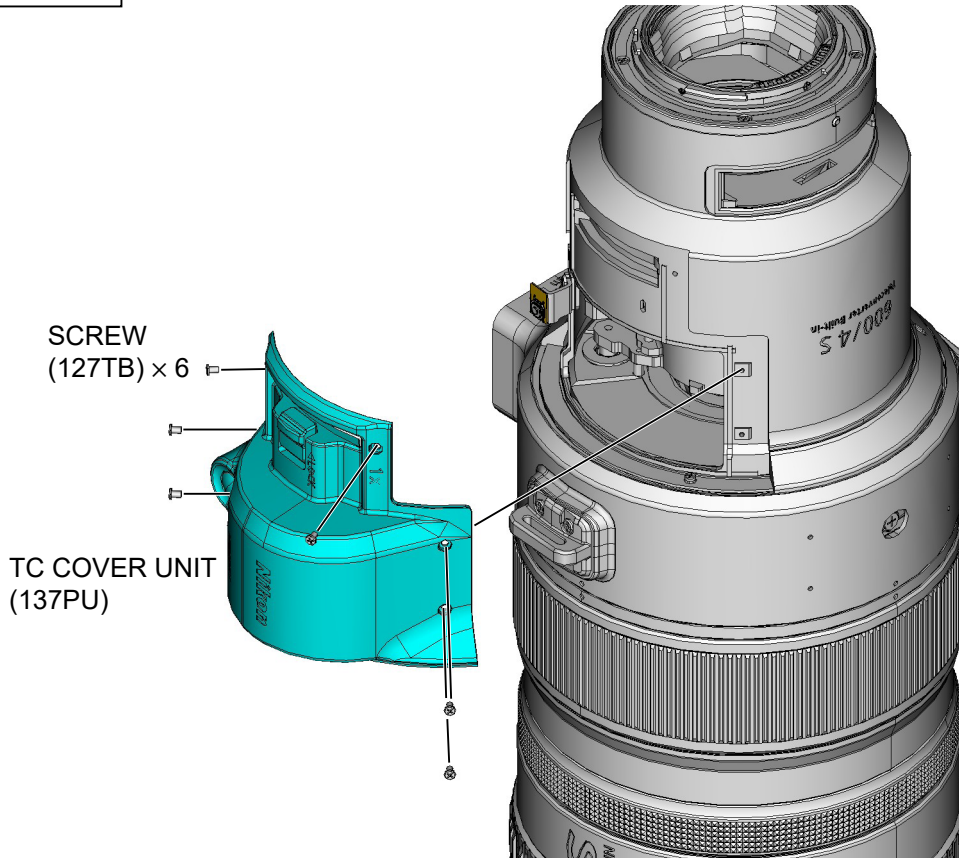

BUTTON HOLDING PLATE

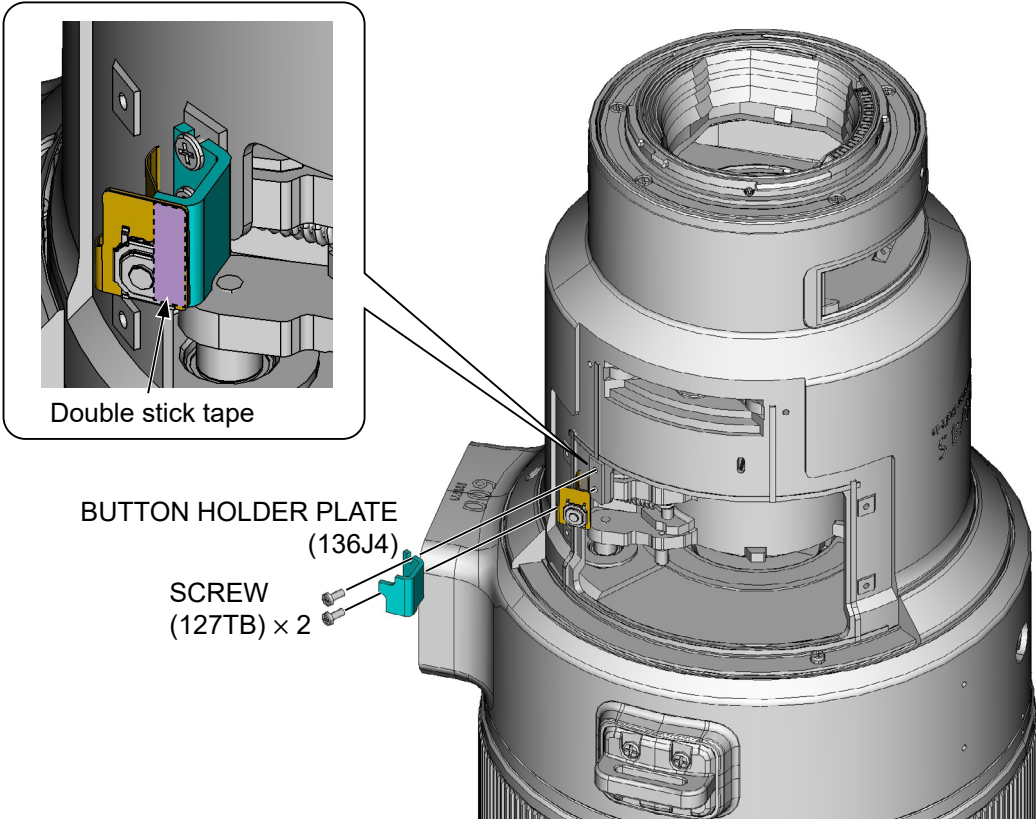

TRIPOD RETAINER RING

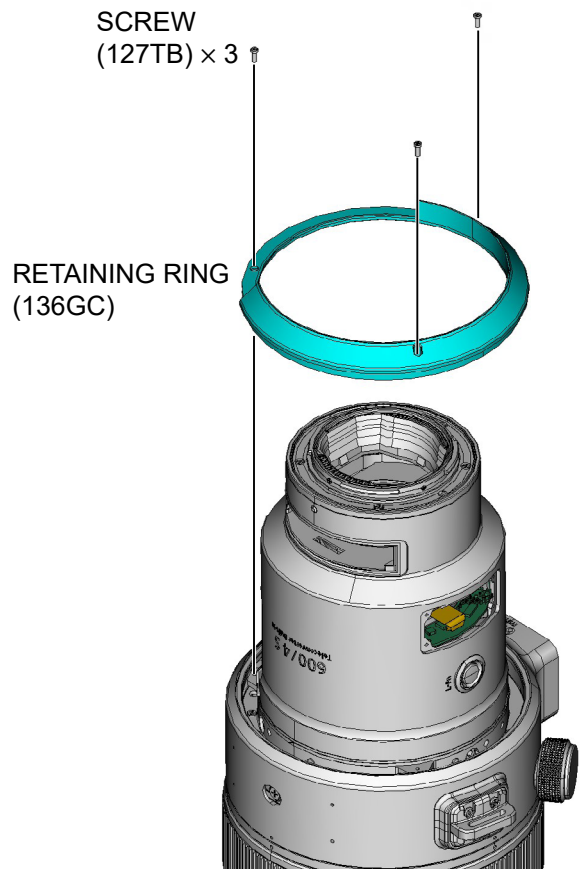

TRIPOD RING UNIT

Rotate the TRIPOD ATTACHING RING UNIT to remove a total of 18 components from the lens.

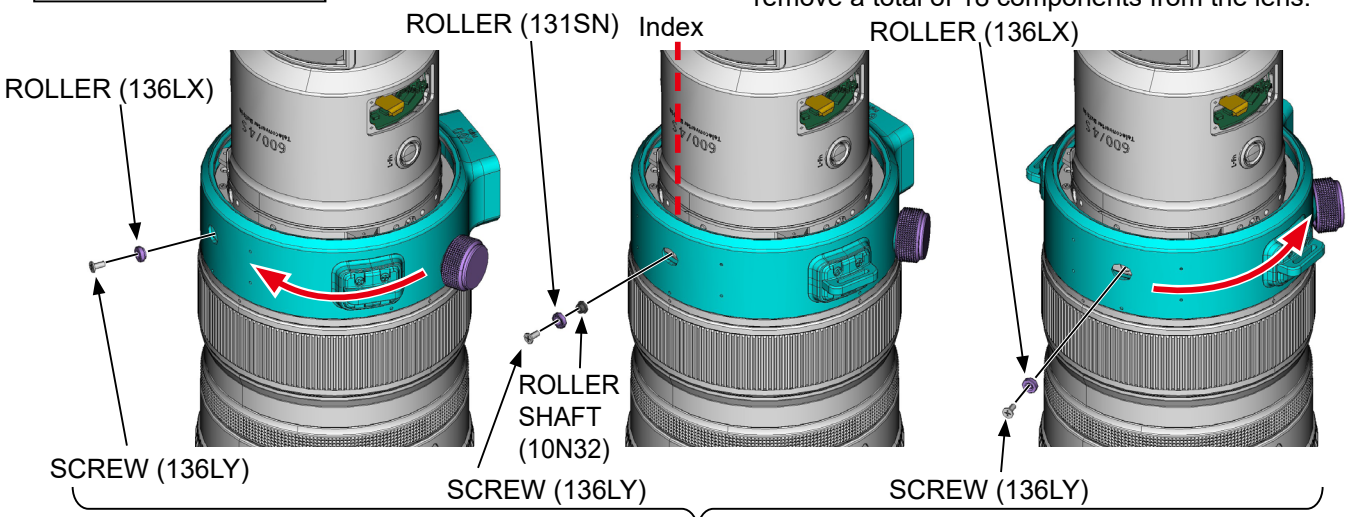

×6  
Index

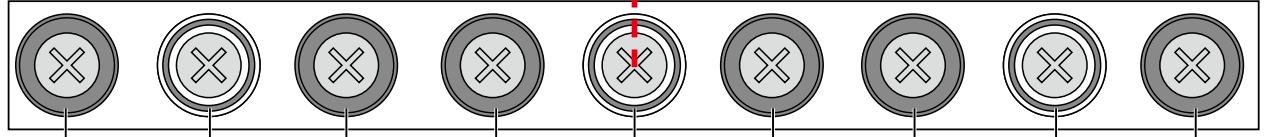

- ROLLER (136LX)
- ROLLER SHAFT (10N32),  
ROLLER (131SN)
- ROLLER (136LX)
- ROLLER (136LX)
- ROLLER SHAFT (10N32),  
ROLLER (131SN)
- ROLLER (136LX)
- ROLLER (136LX)
- ROLLER SHAFT (10N32),  
ROLLER (131SN)
- ROLLER (136LX)

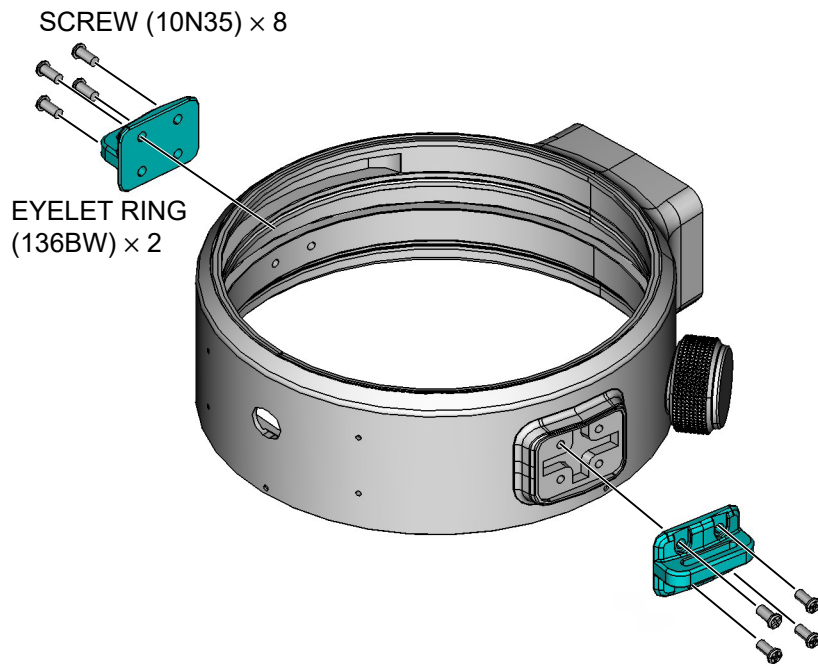
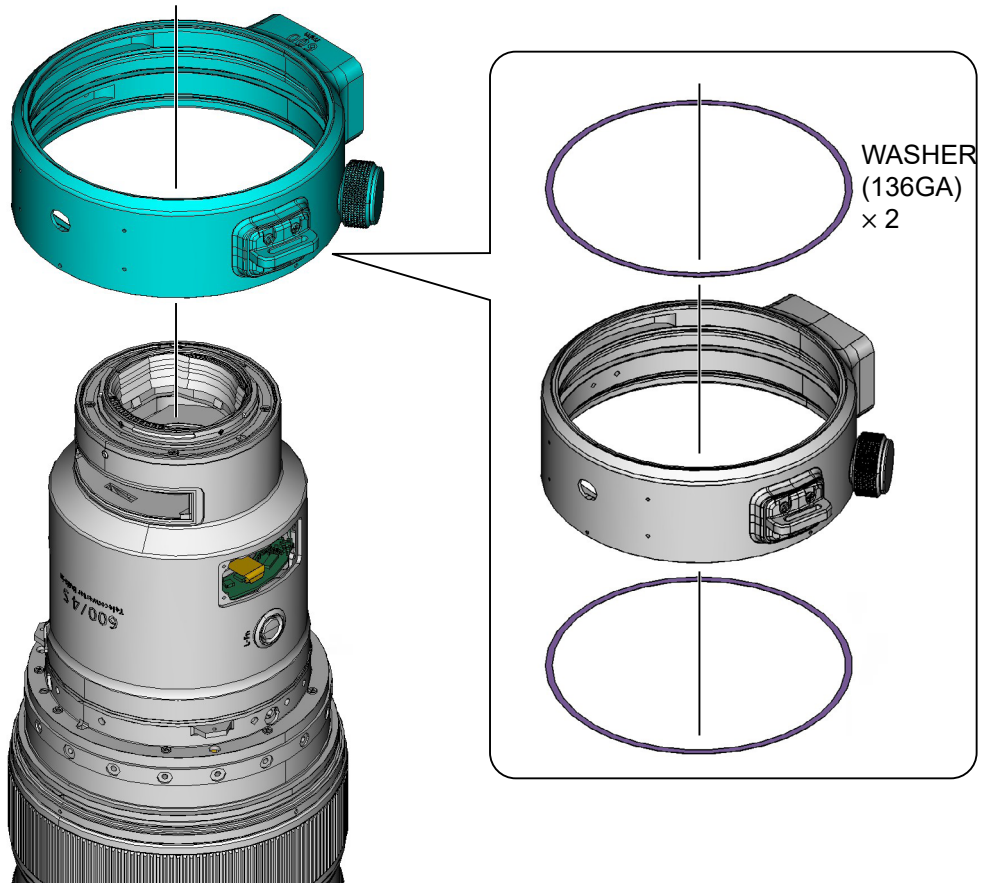

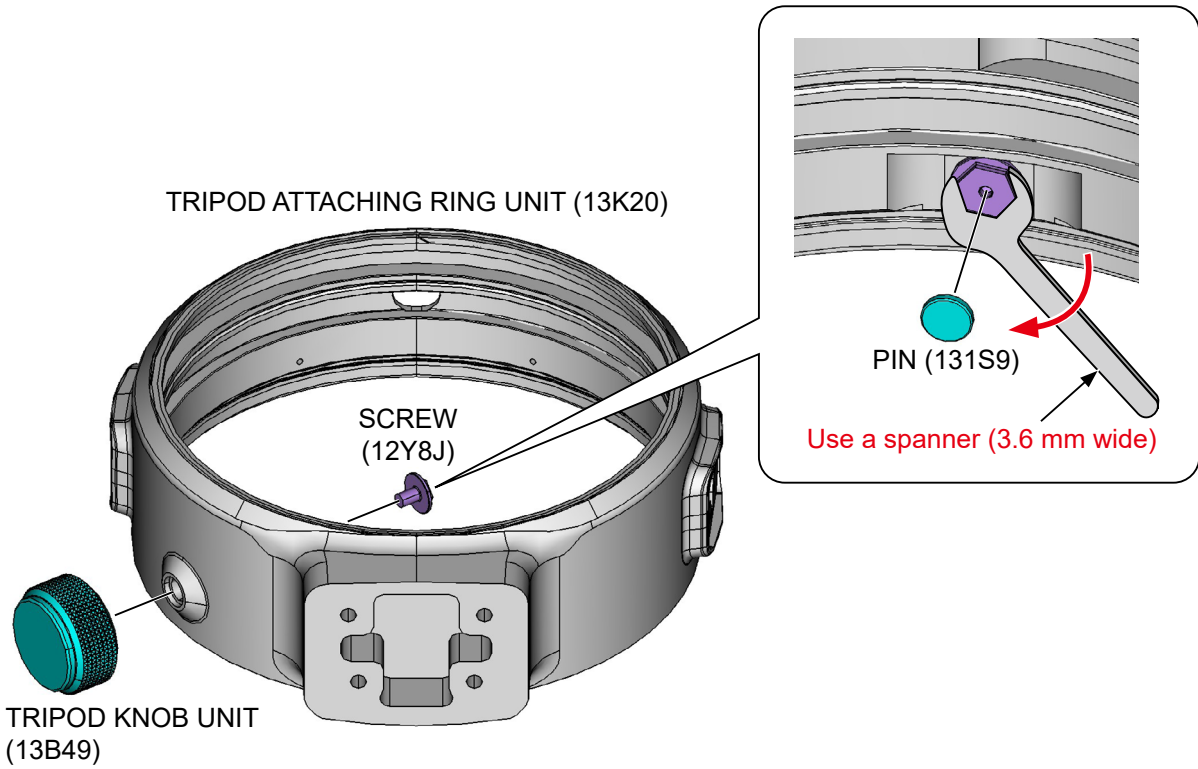

REAR COVER RING UNIT

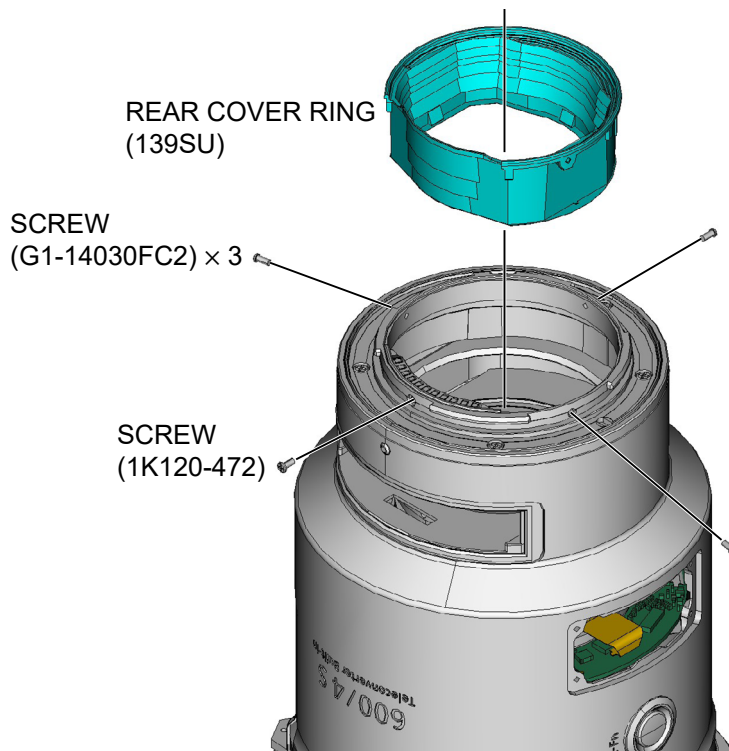

MOUNT

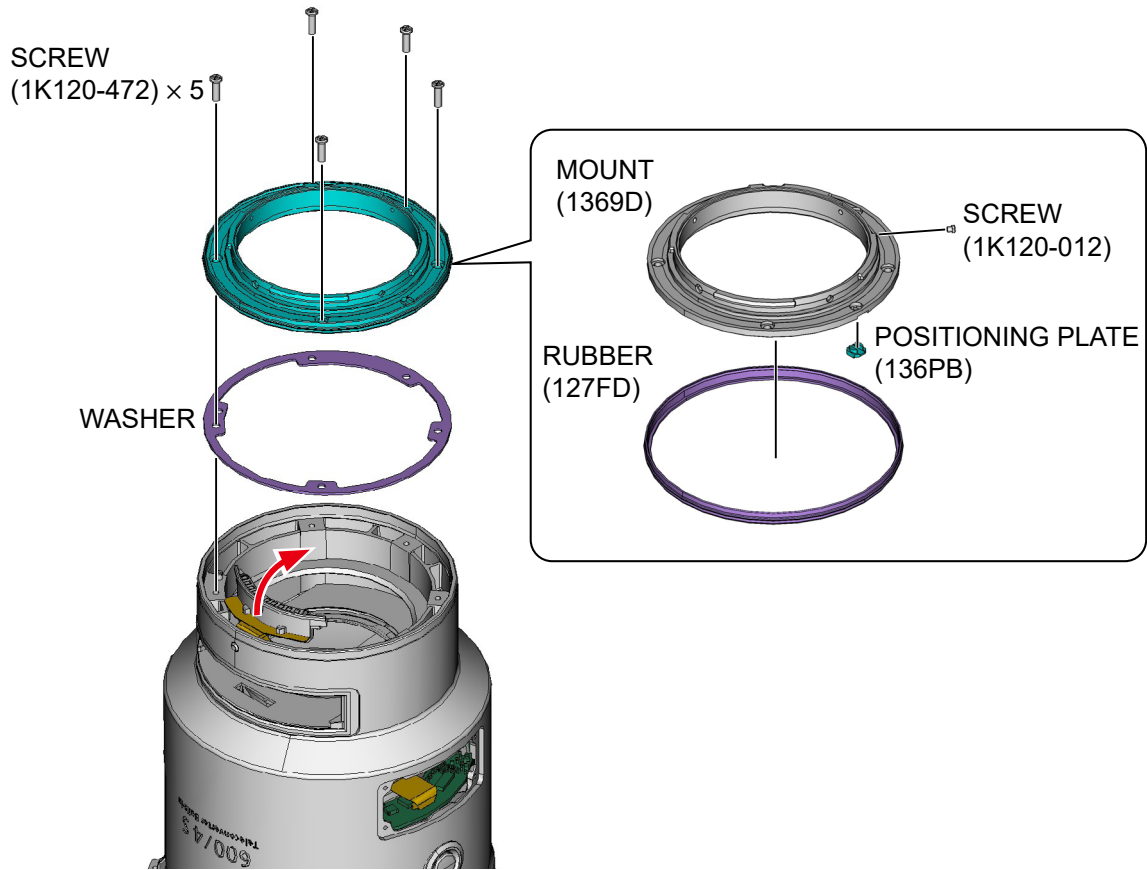

FILTER FRAME

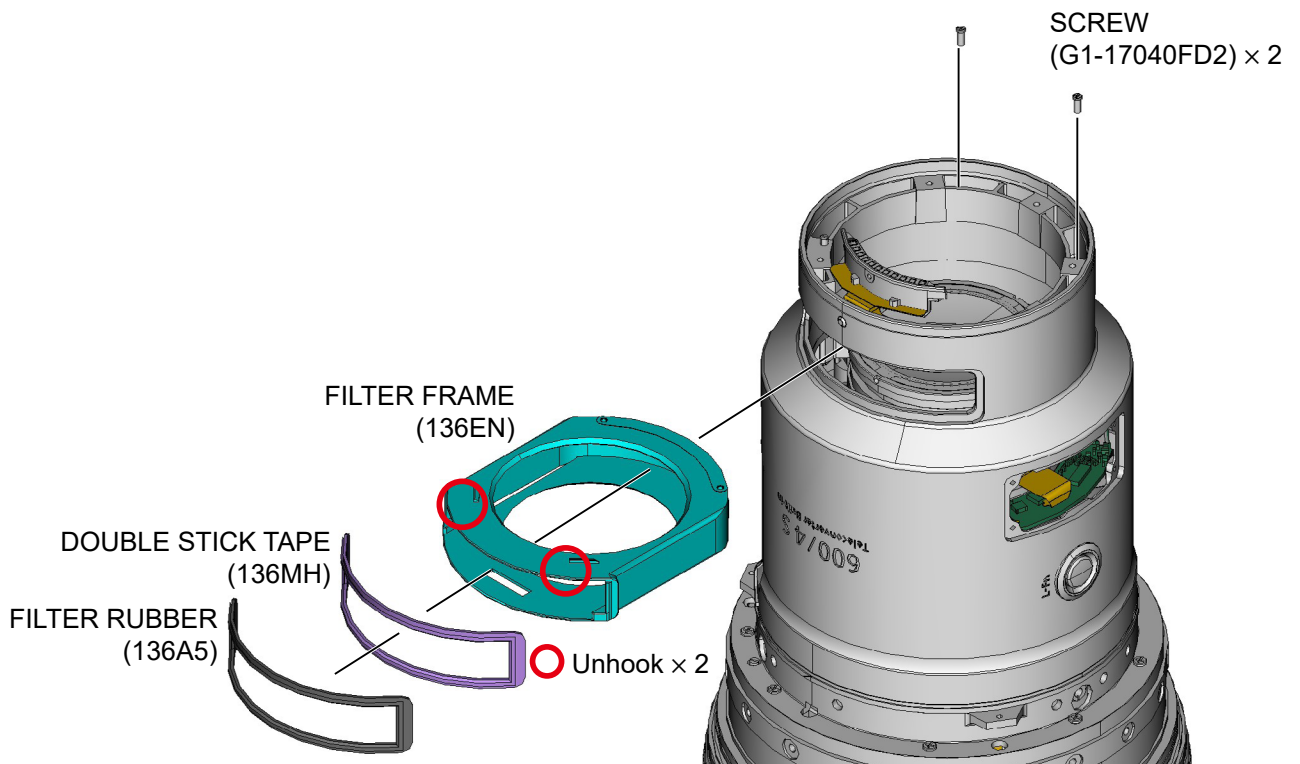

REAR TUBE UNIT

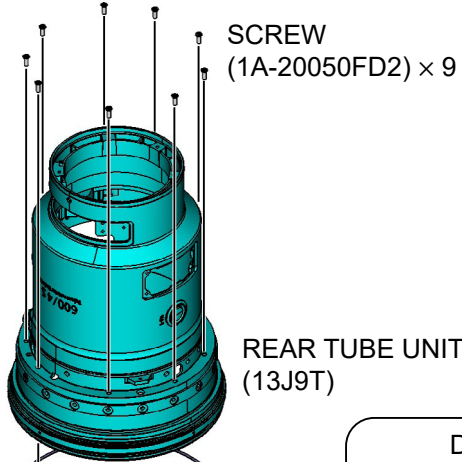

WASHER  
(Contains a WASHER with one of the following item codes.)

Item code	Parts name
136LD	WASHER
136LE	WASHER
136LF	WASHER
136LG	WASHER
136LH	WASHER
136LJ	WASHER
136LK	WASHER

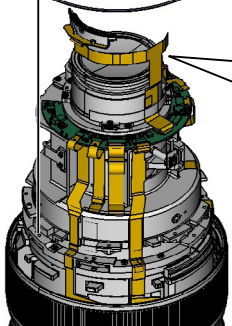
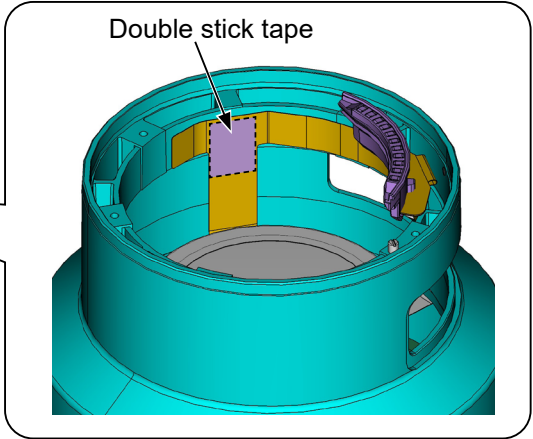

CONTACT UNIT

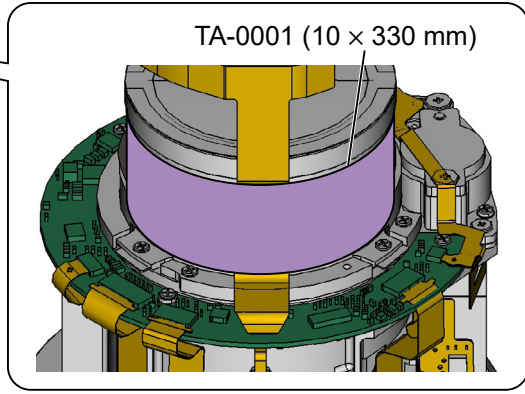
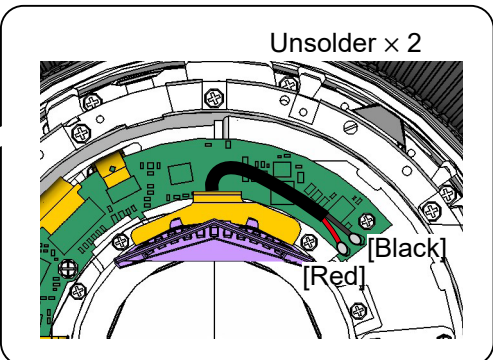
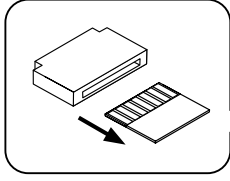
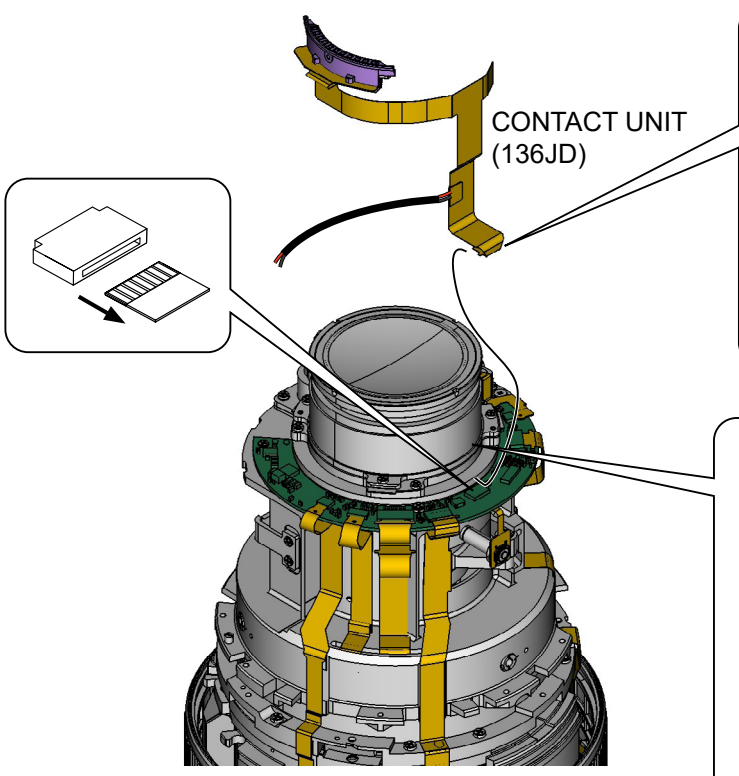

MF RING UNIT

WASHER  
(136JC)

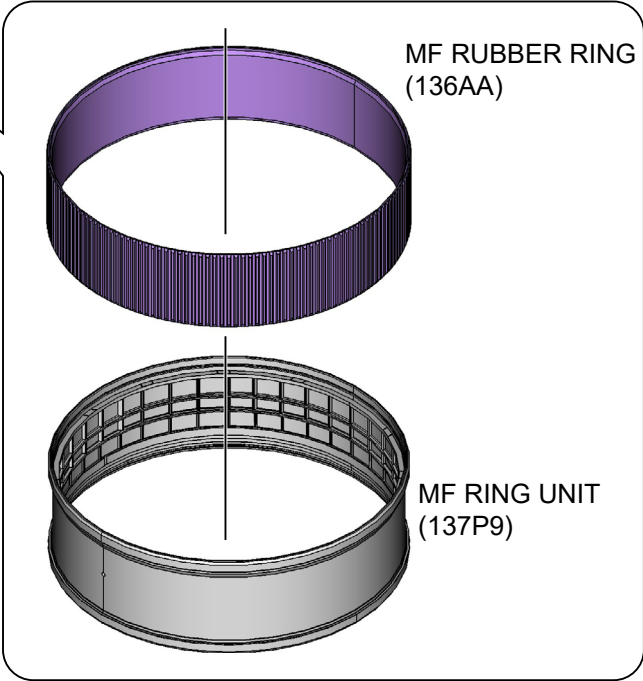
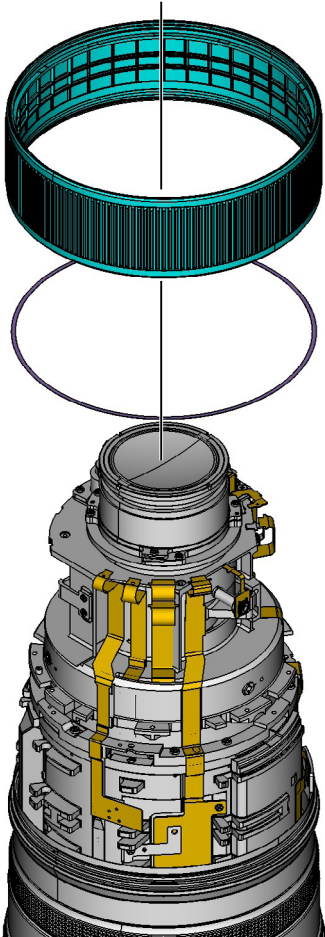

MF RUBBER RING  
(136AA)

MF RING UNIT  
(137P9)

TC DRIVING UNIT

TC DETECTION UNIT  
(129C8)

SCREW (1A-14030FB)

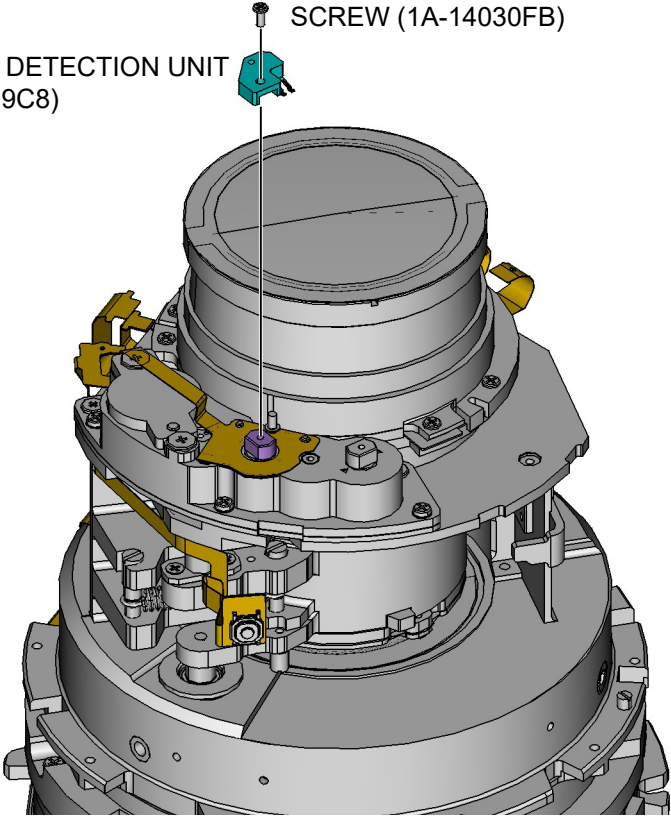

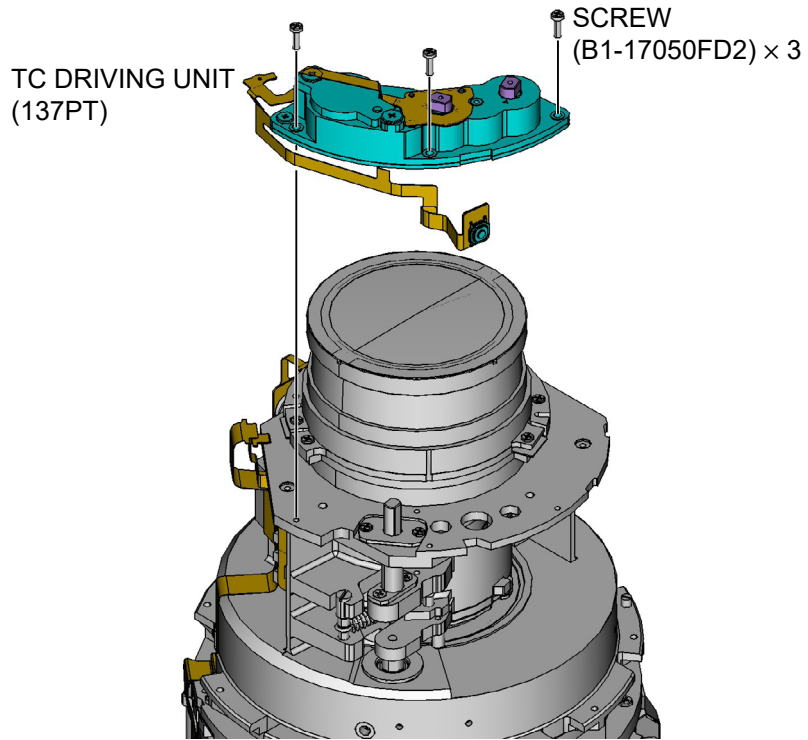

FN RUBBER RING

FN RUBBER RING  
(136A6)

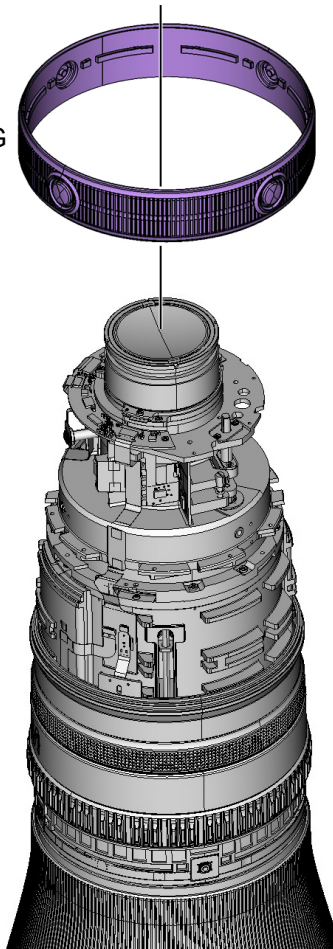

GRIP RUBBER RING

GRIP RUBBER RING  
(1399M)

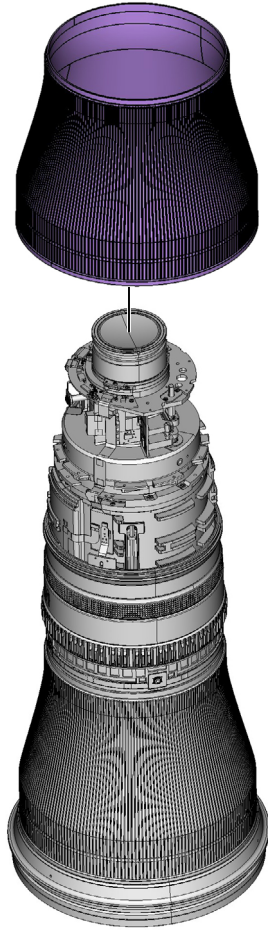

---

FRONT RUBBER

FRONT RUBBER  
(116L6)

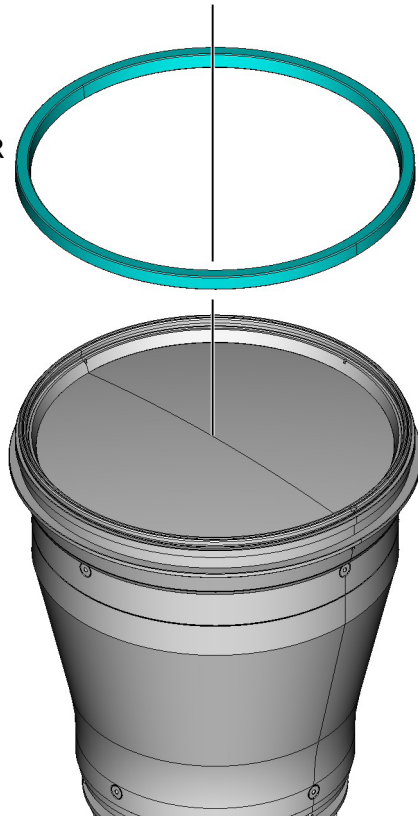

HOOD MOUNTING RING

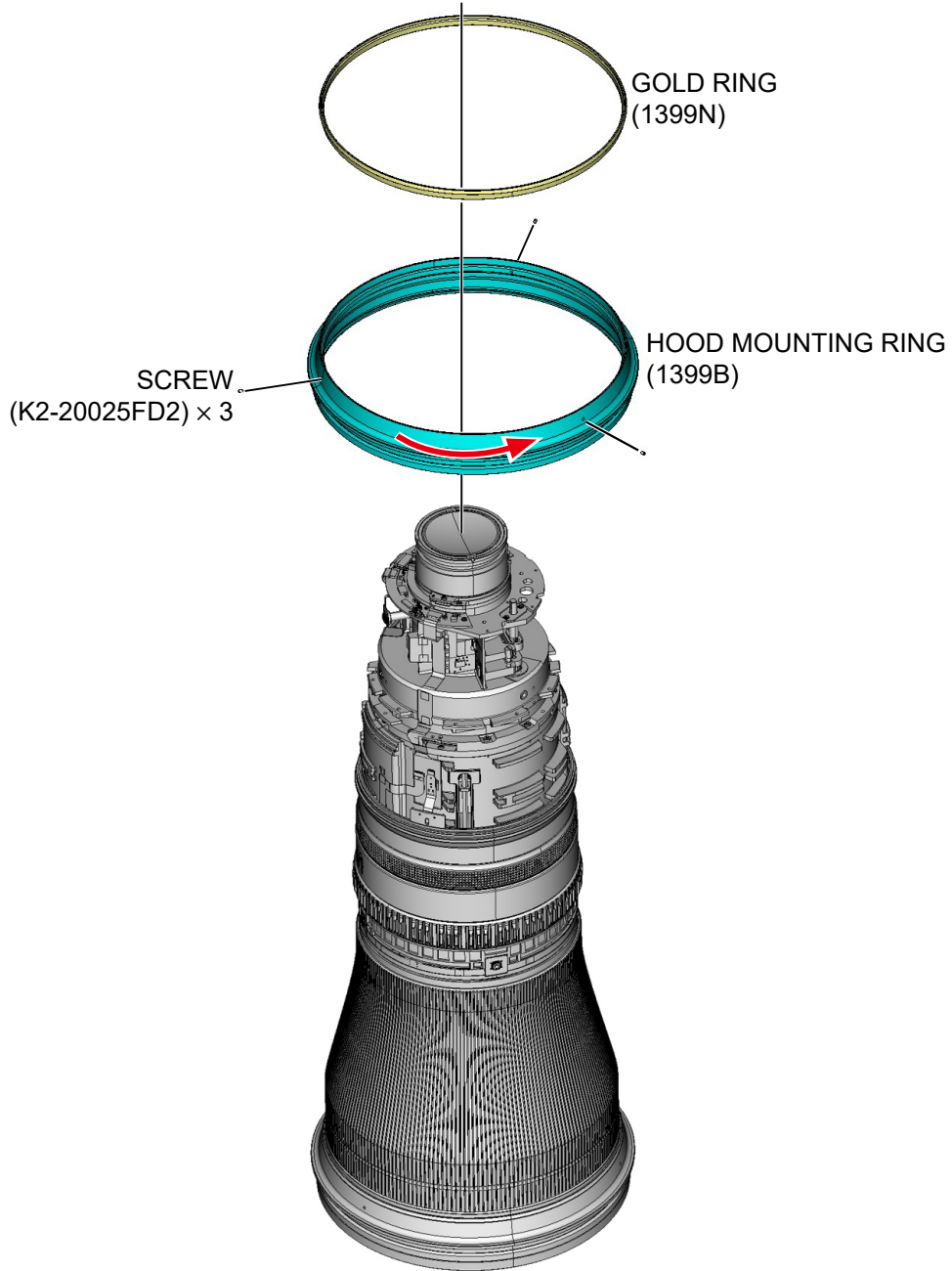

# Assembly

## HOOD MOUNTING RING

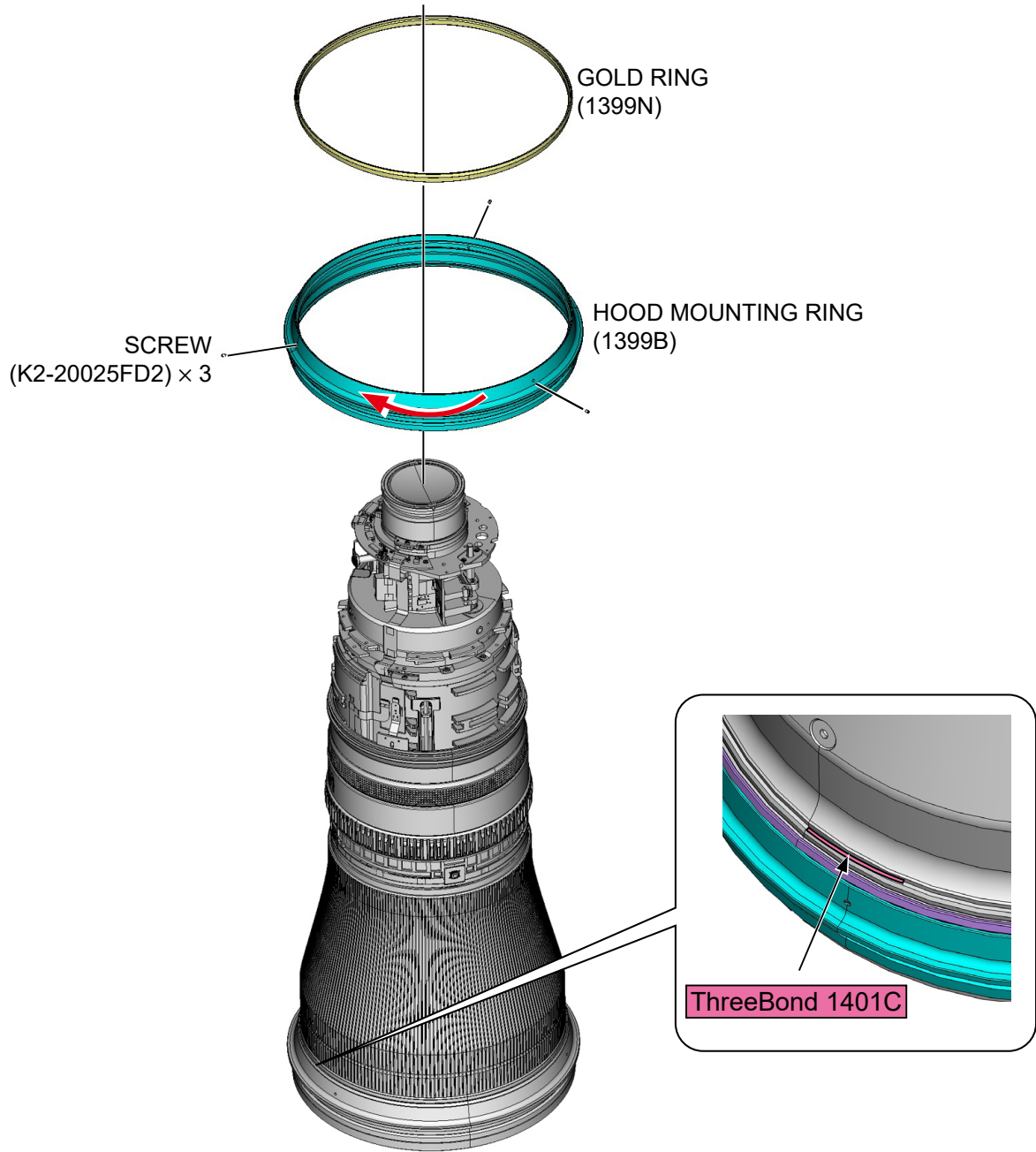

FRONT RUBBER

FRONT RUBBER  
(116L6)

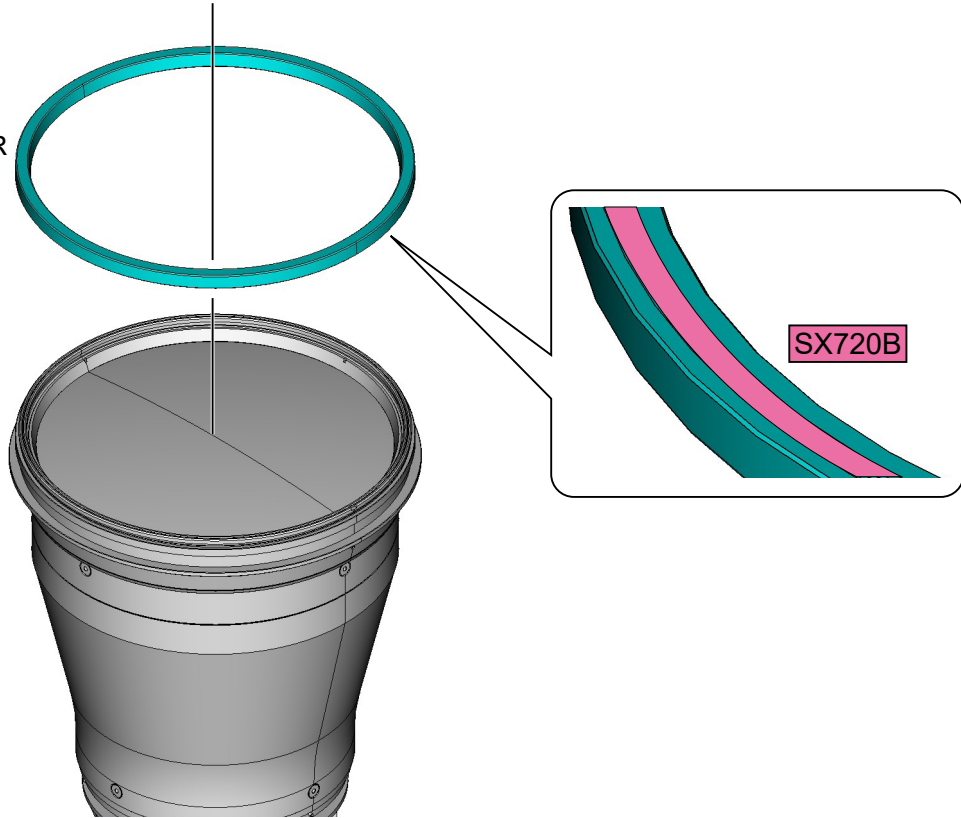

---

GRIP RUBBER RING

GRIP RUBBER RING  
(1399M)

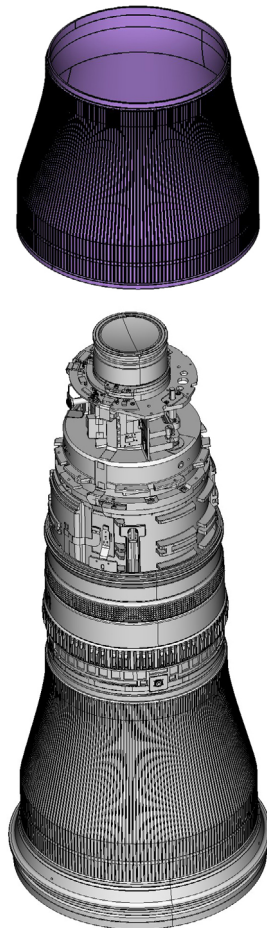

FN RUBBER RING

FN RUBBER RING  
(136A6)

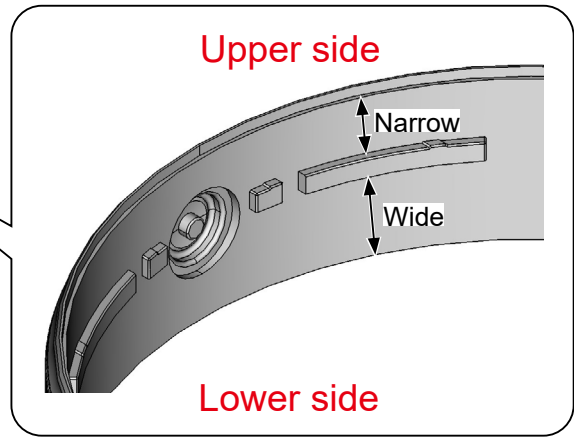
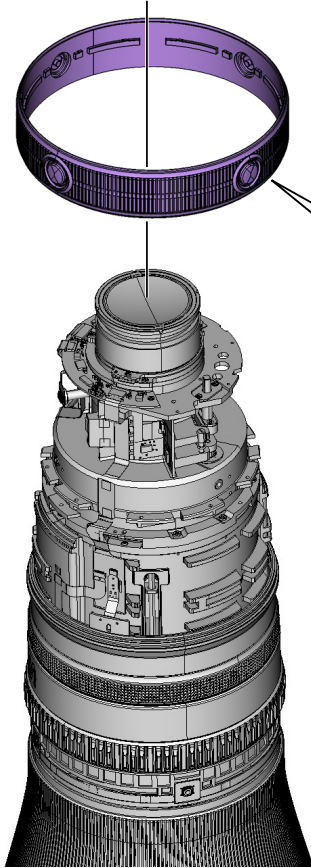

TC DRIVING UNIT

SCREW (B1-17050FD2) × 3  
0.15 N·m

Adjust to the position  
shown below

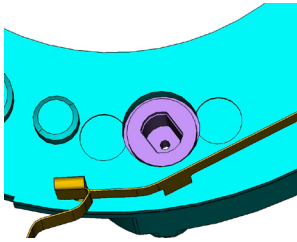

TC DRIVING  
UNIT  
(137PT)

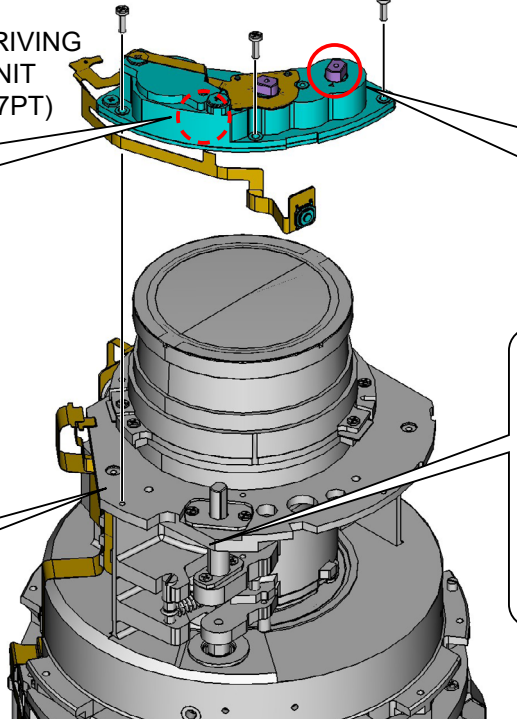

Adjust to the position  
shown below

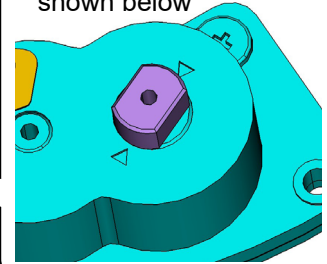

Double stick tape

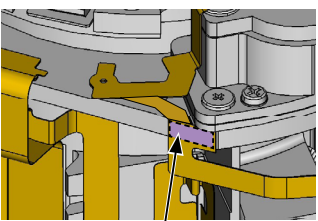

Double stick tape

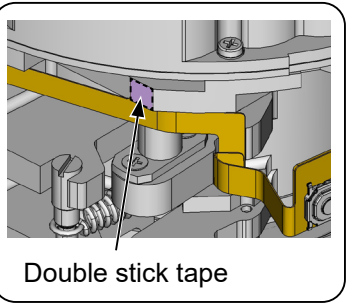

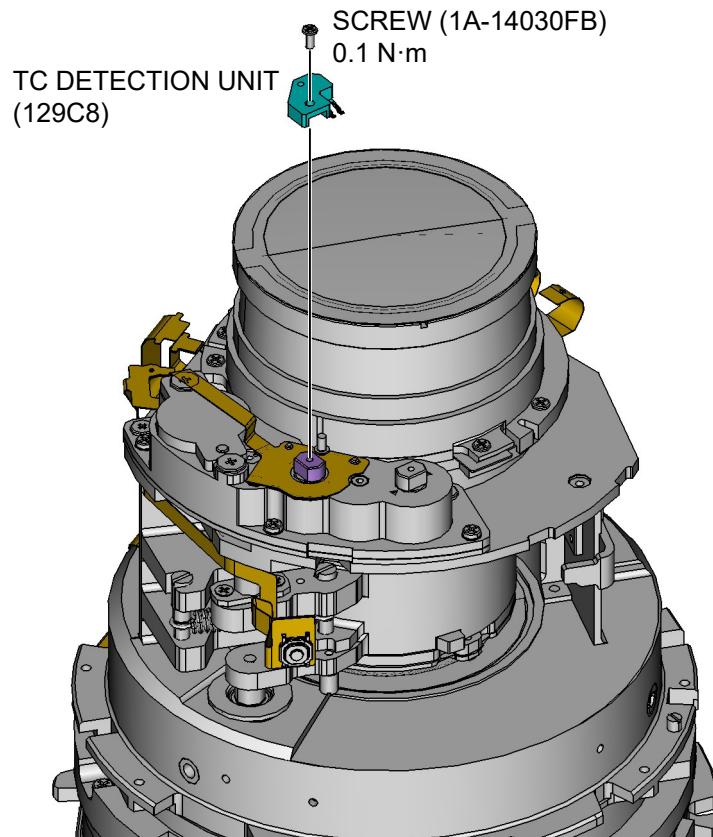

MF RING UNIT

MF RUBBER RING  
(136AA)

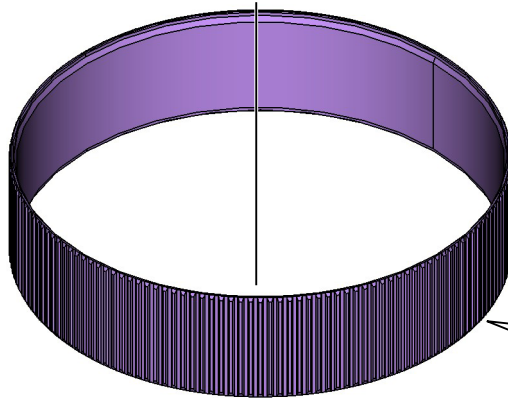

MF RING UNIT  
(137P9)

MDF-400T

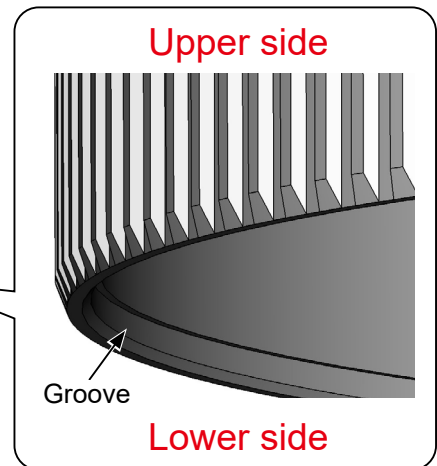
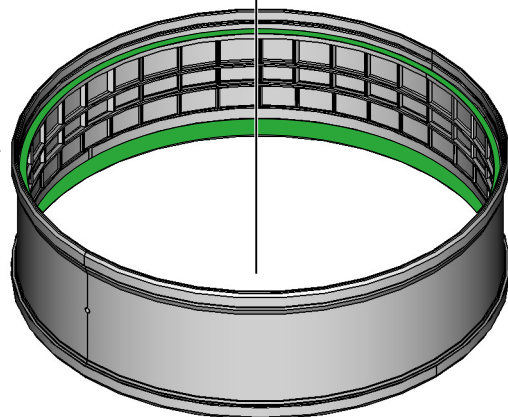

WASHER  
(136JC)

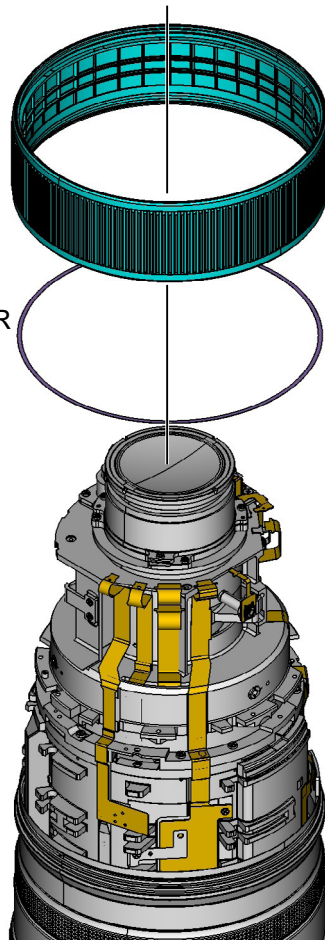

CONTACT UNIT

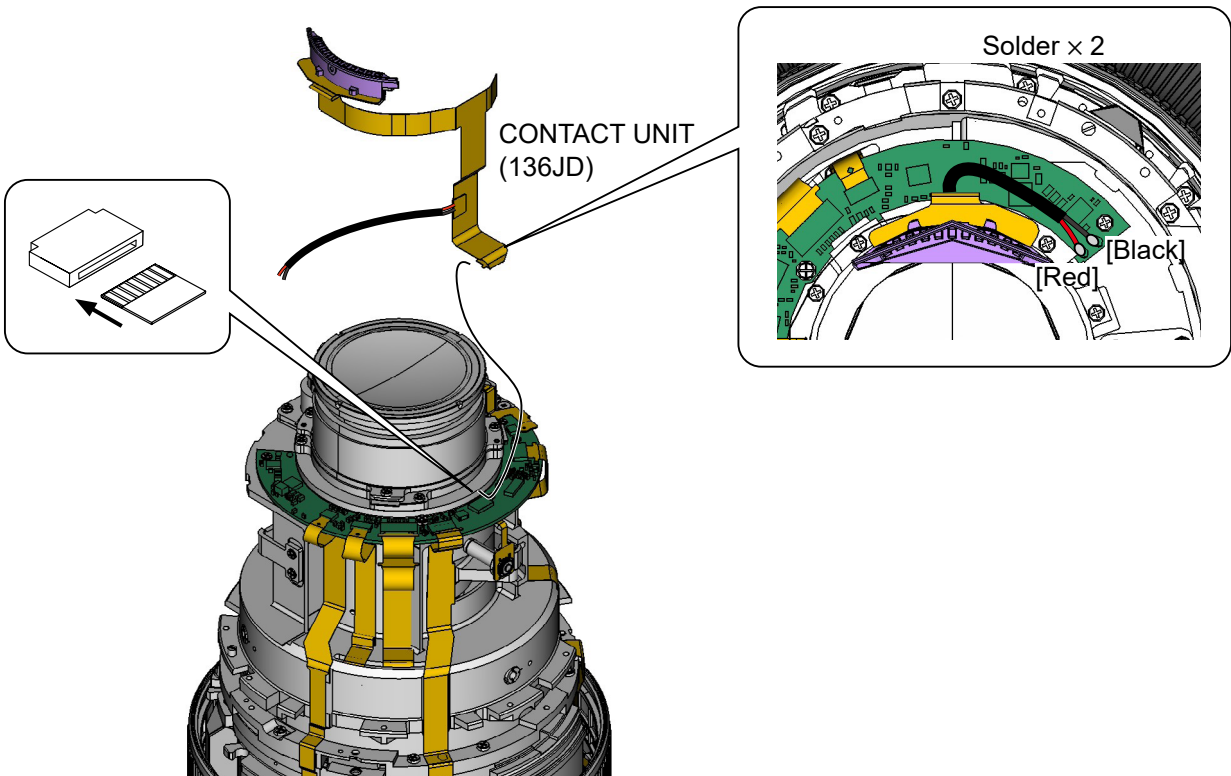

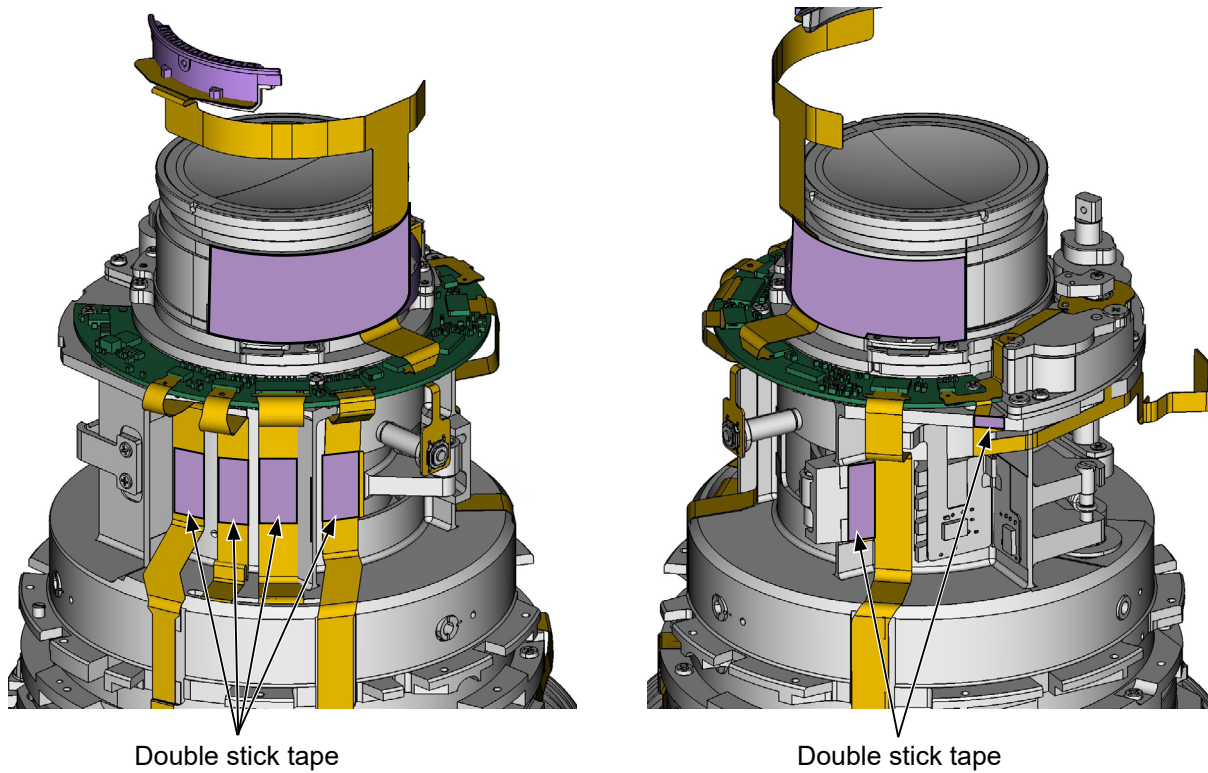
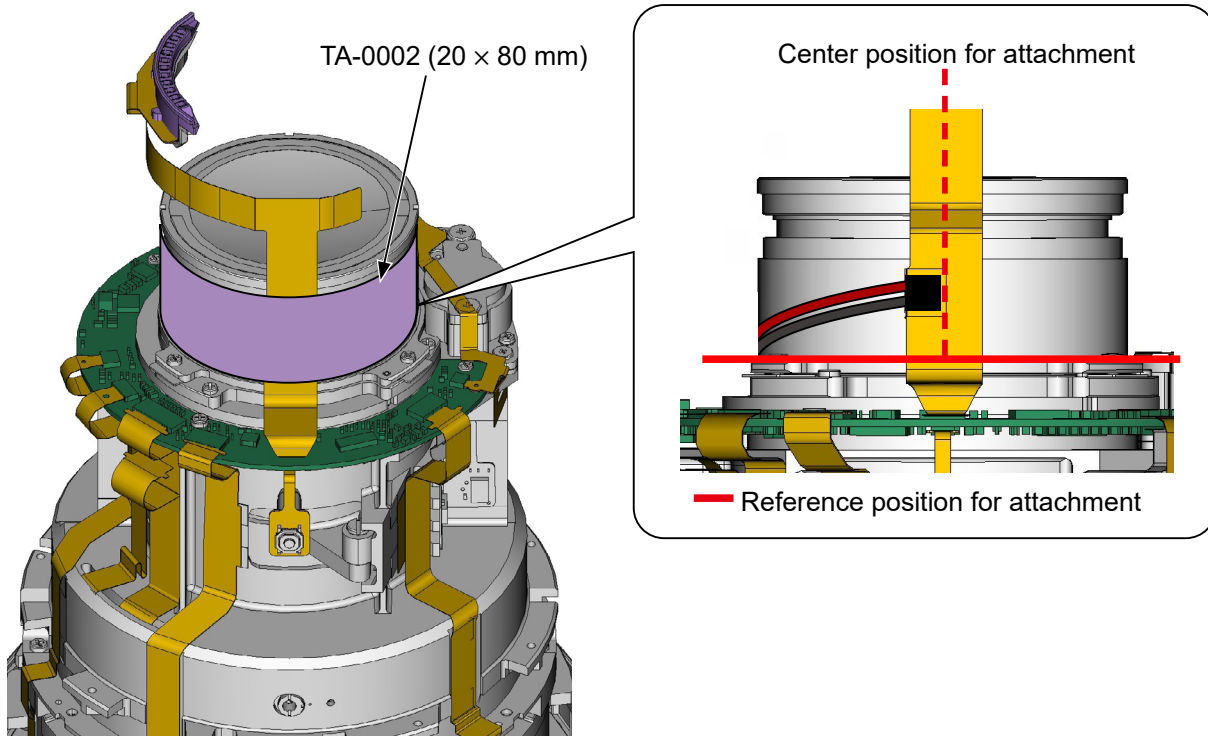

REAR TUBE UNIT

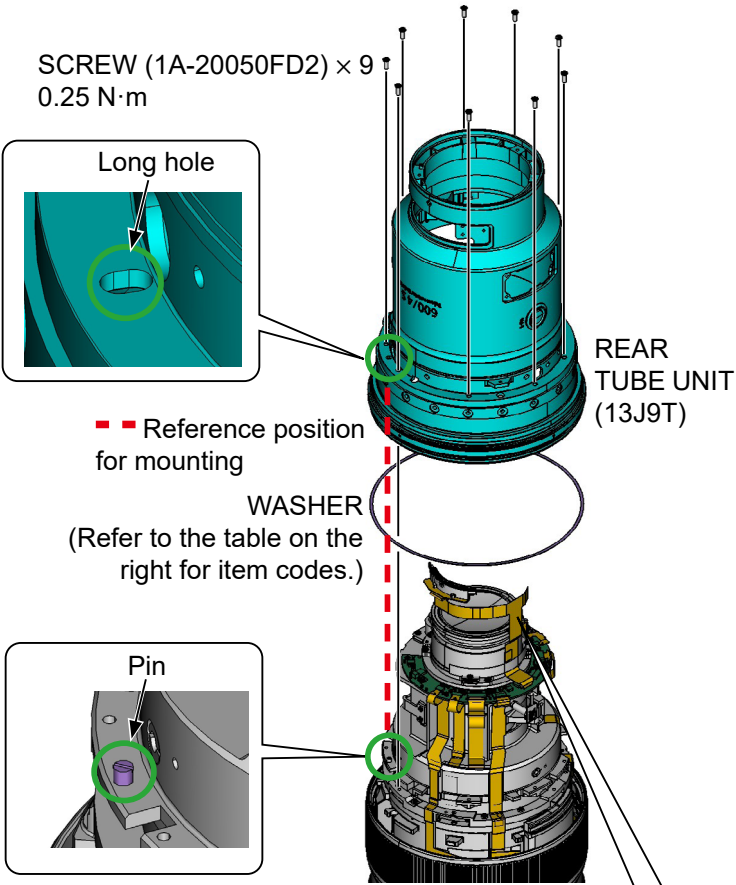

Item code	Parts name	Thickness *
136LD	WASHER	A
136LE	WASHER	B
136LF	WASHER	C
136LG	WASHER	D
136LH	WASHER	E
136LJ	WASHER	F
136LK	WASHER	G

\* Thickness increases in order from A (thinnest) to G (thickest).

- If you replace the REAR TUBE UNIT, you will need to adjust the WASHER size. To adjust the operation after assembling, use intermediate-size WASHER (136LG) when assembling.
- Rotate the MF RING UNIT and check the operating characteristics. If the operation feels heavy, replace the washer with a thinner one. If the operation feels light, replace the washer with a thicker one.
- When replacing the WASHER, select one that does not cause backlash.
- There is 1 or *n* item(s) in this part.

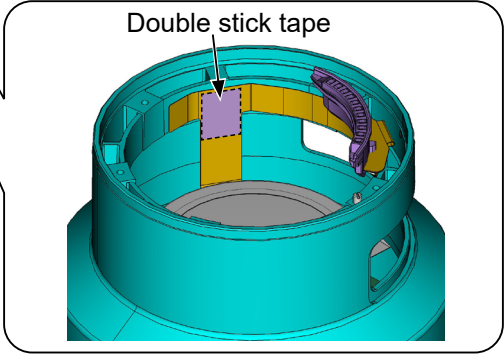

FILTER FRAME

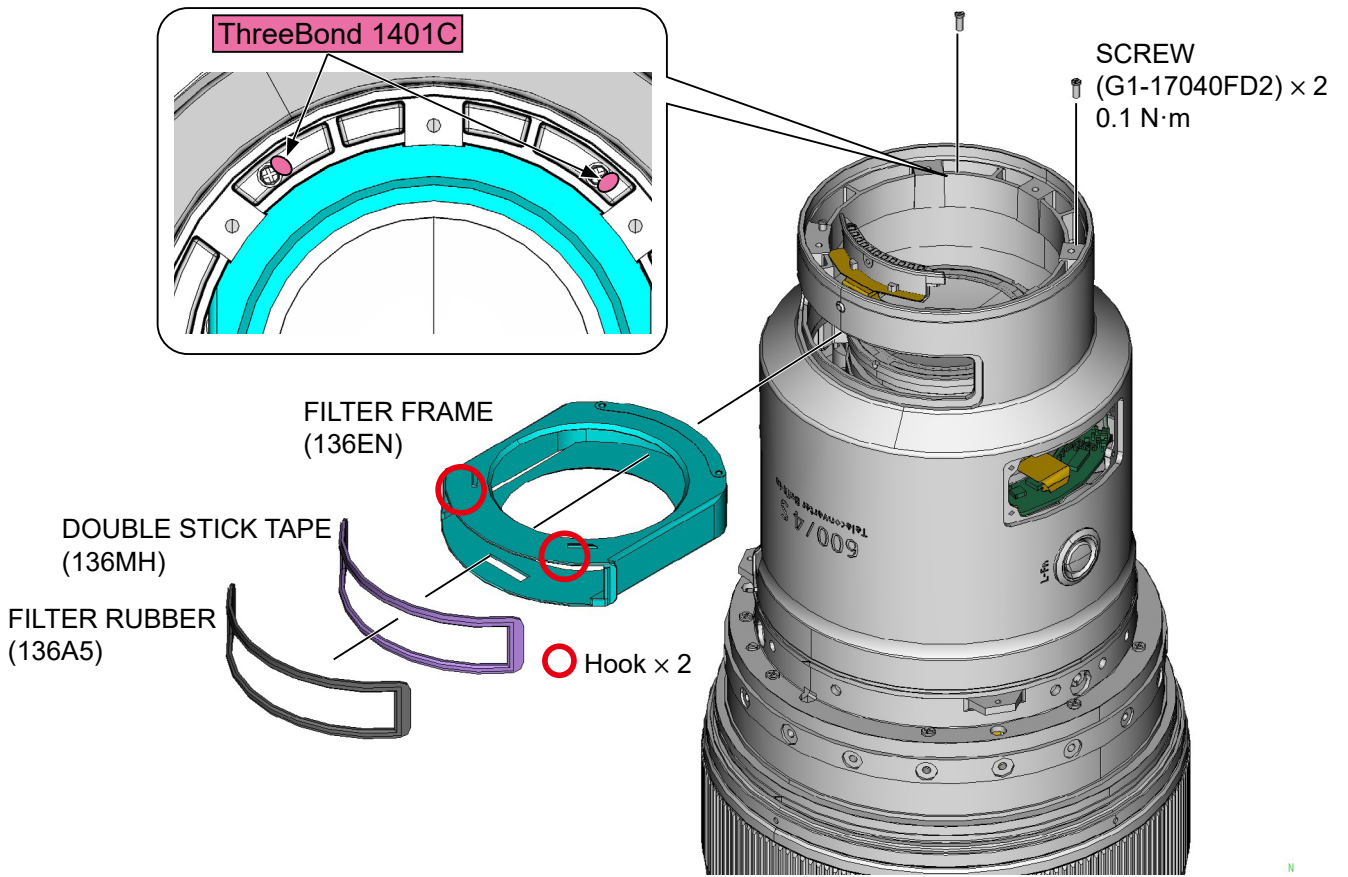

MOUNT

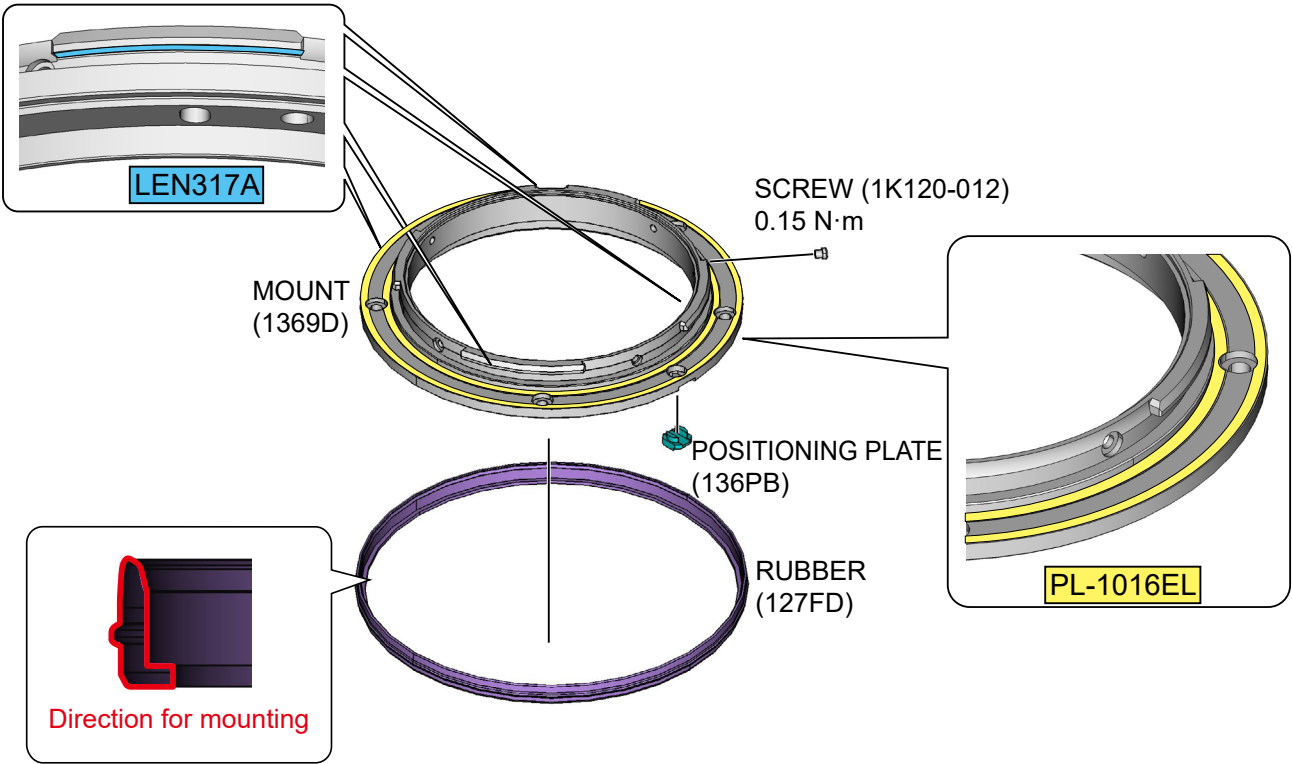

SCREW (1K120-472) × 5  
0.25 N·m

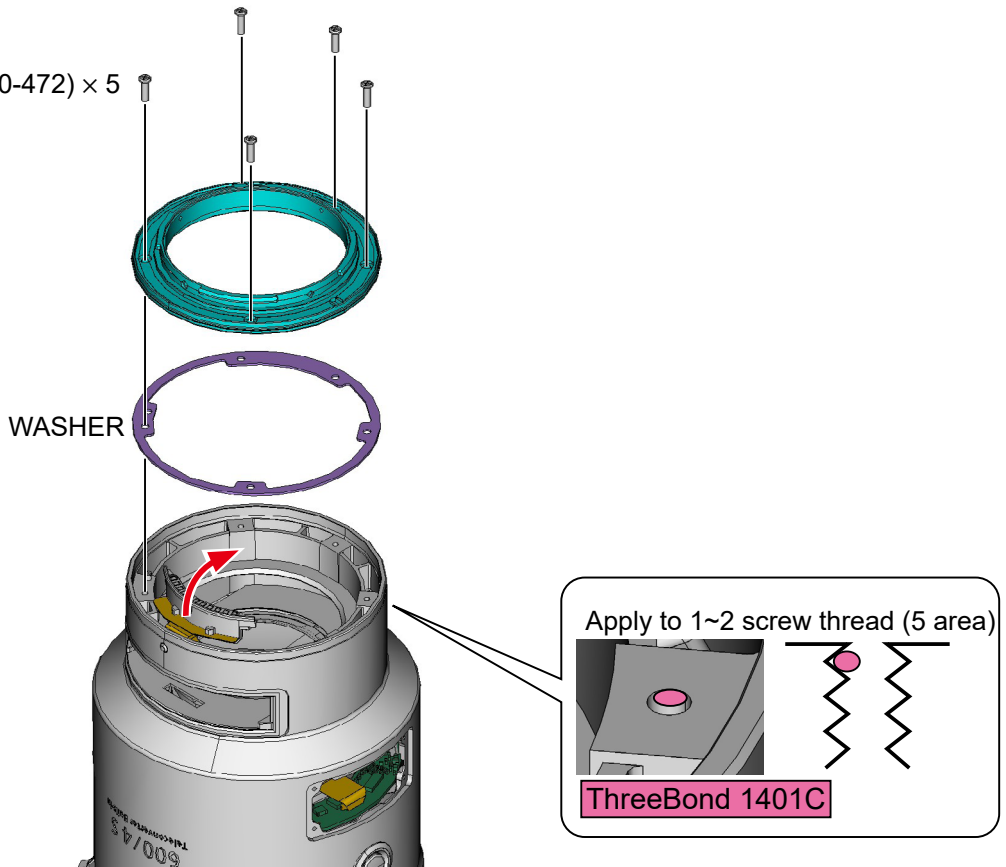

REAR COVER RING UNIT

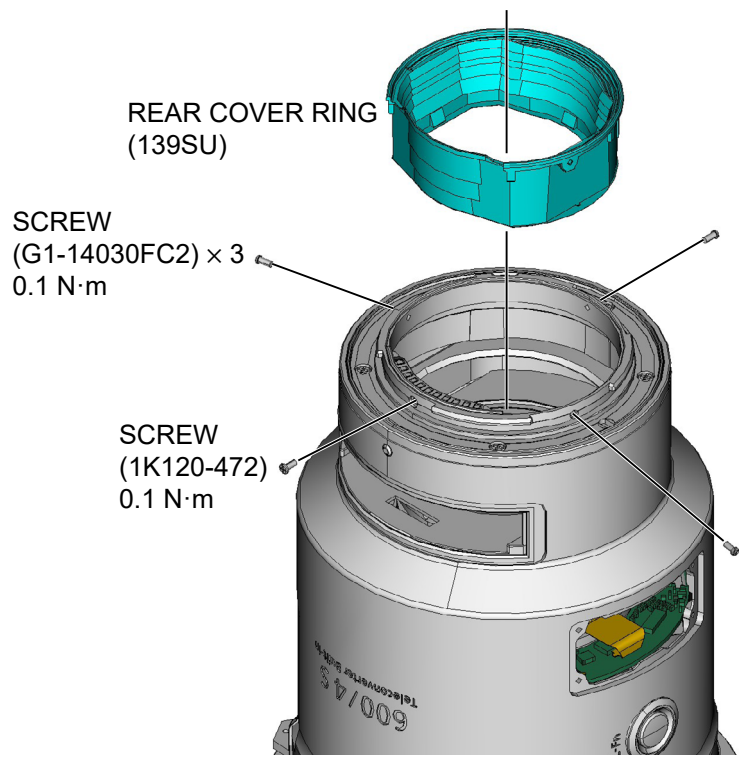

TRIPOD RING UNIT

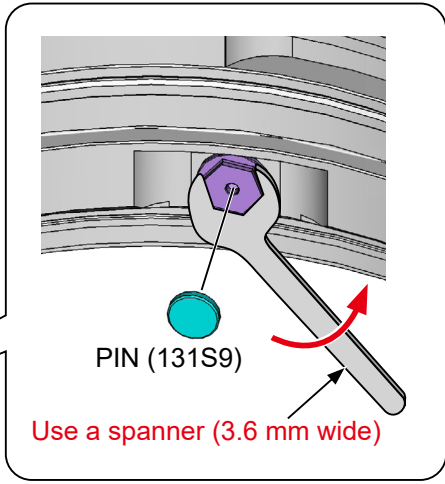
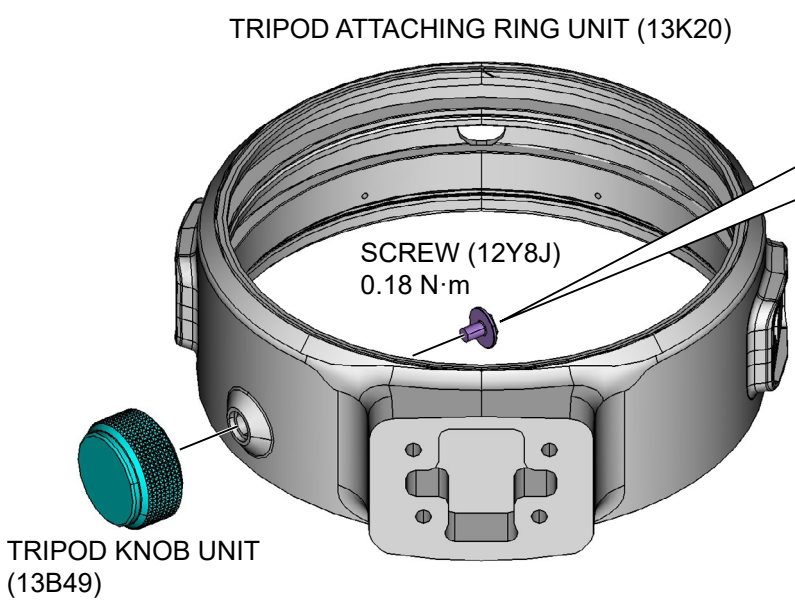

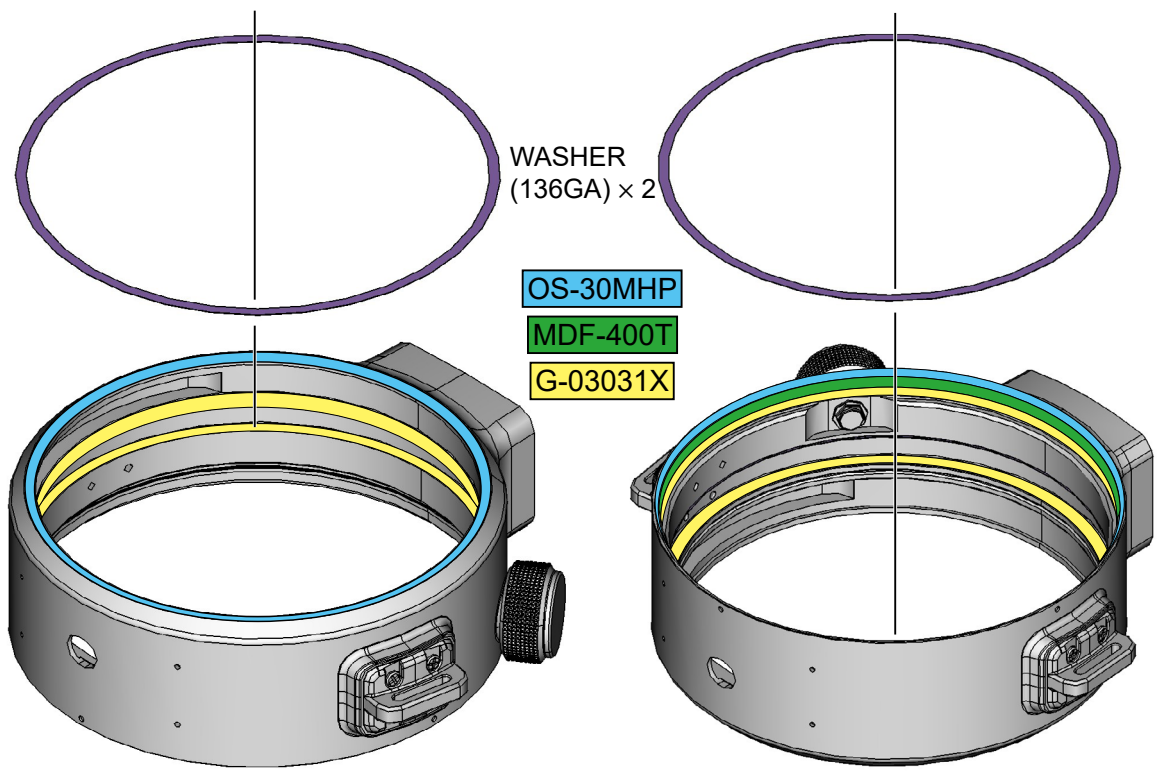
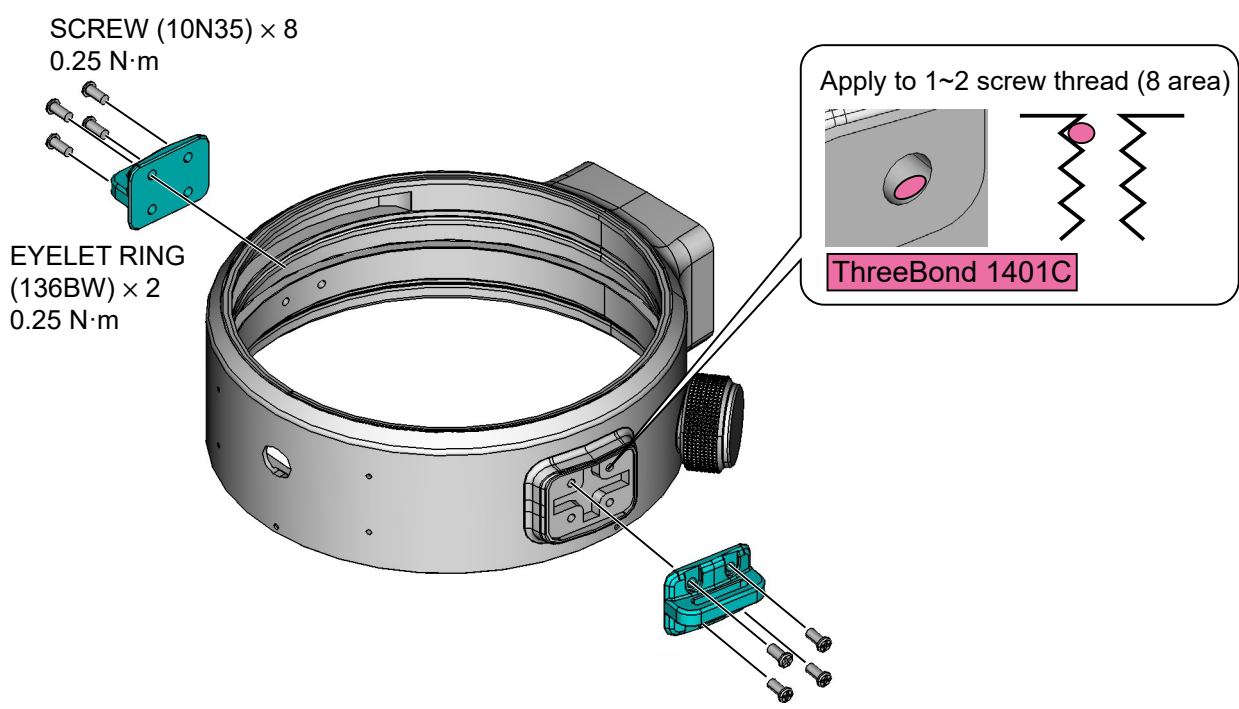

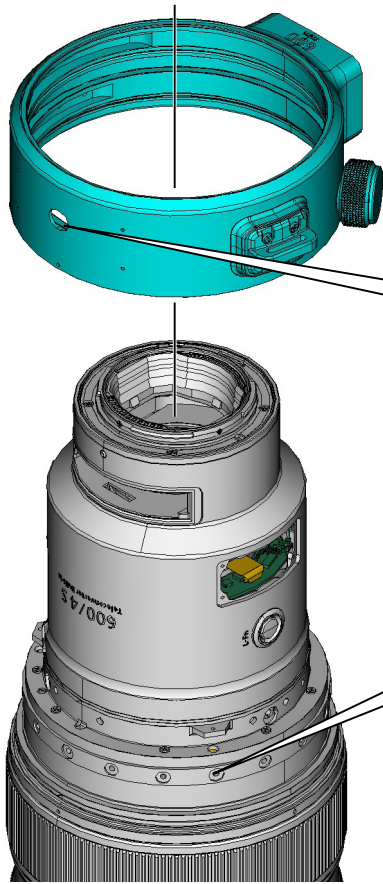

Make sure that the WASHER (136GA) × 2 is attached separately on the top and bottom.

**OK**

WASHER (136GA) × 2

**NG**

WASHER (136GA) × 2

Apply to 1~2 screw thread (18 area)

**ThreeBond 1401C**

Rotate the TRIPOD ATTACHING RING UNIT to attach a total of 18 components to the lens.

ROLLER (136LX)

ROLLER (131SN) Index

ROLLER SHAFT (10N32)

ROLLER (136LX)

SCREW (136LY)

SCREW (136LY)

SCREW (136LY)

**×6**  
Index

ROLLER (136LX) ROLLER (10N32), ROLLER (131SN) ROLLER (136LX) ROLLER (136LX) ROLLER (10N32), ROLLER (131SN) ROLLER (136LX) ROLLER (136LX) ROLLER (10N32), ROLLER (131SN) ROLLER (136LX)

TRIPOD RETAINER RING

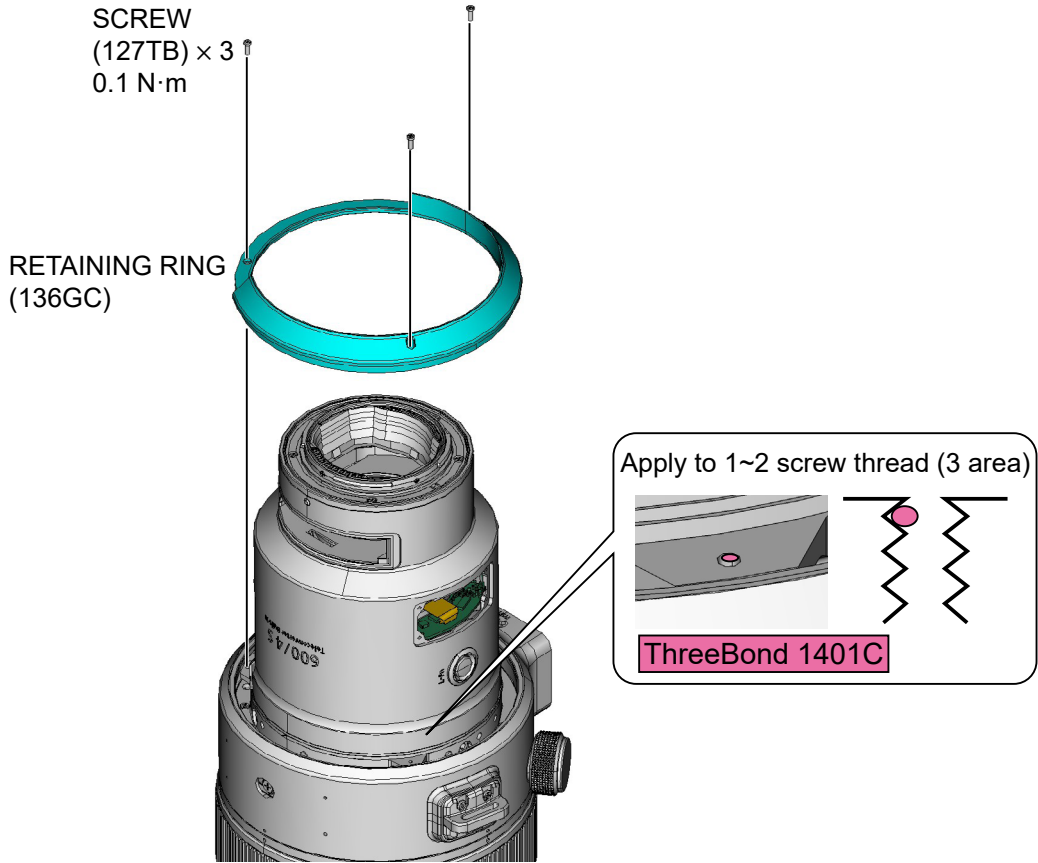

BUTTON HOLDING PLATE

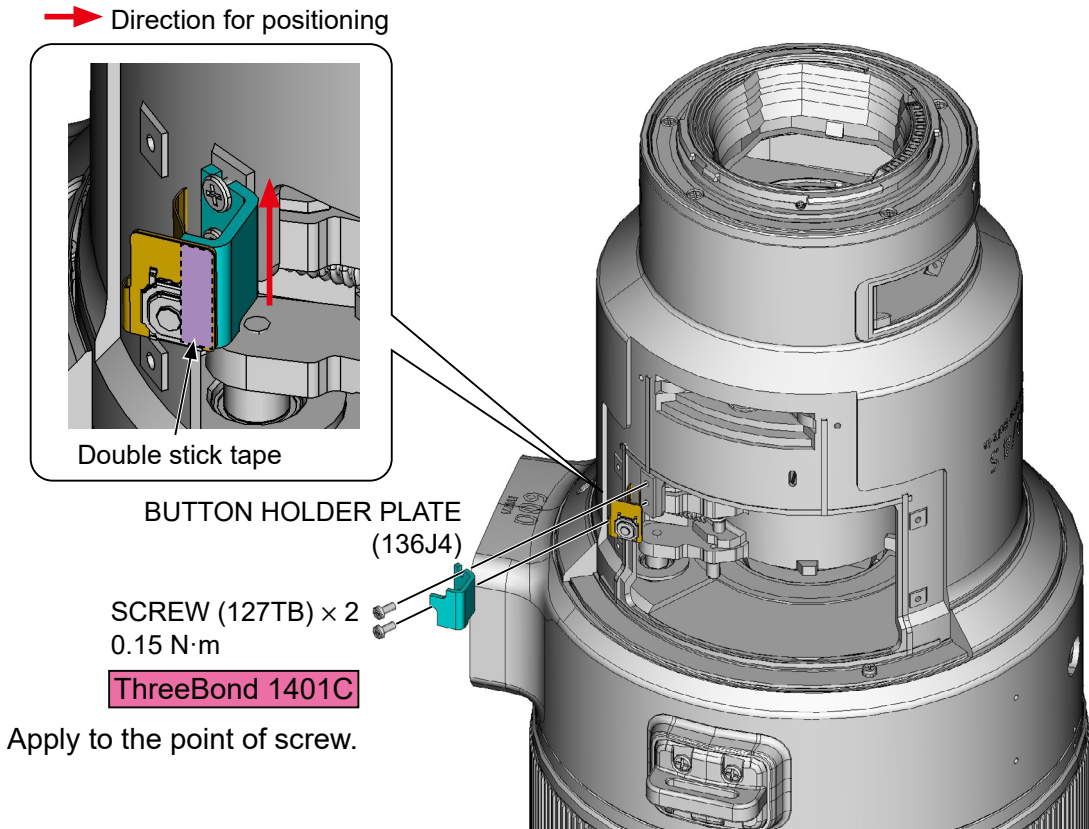

TC COVER UNIT

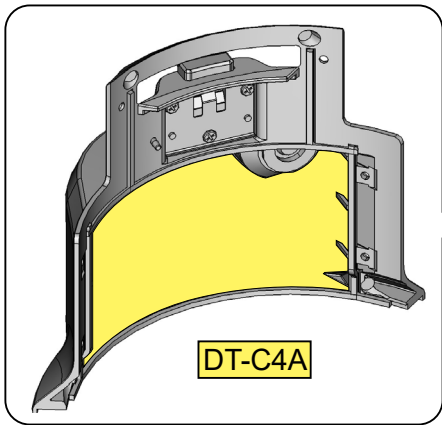

TC COVER UNIT  
(137PU)

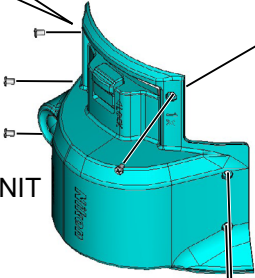

SCREW (127TB) × 6  
0.1 N·m

ThreeBond 1401C

Apply to the point of screw.

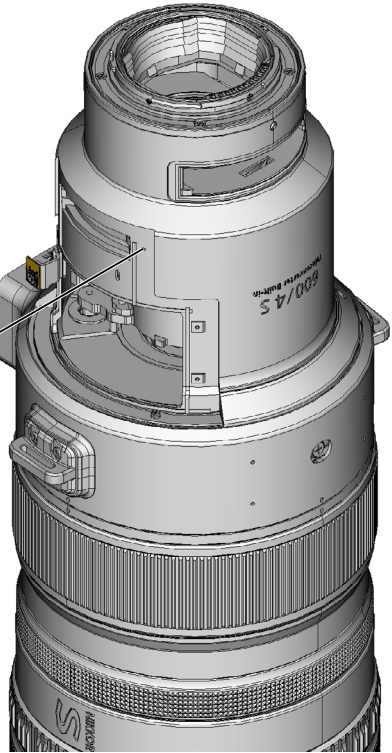

TC LEVER

TC LEVER  
(136G1)

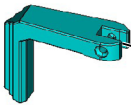

SCREW  
(B2-17060FD2)  
0.2 N·m

LOCTITE 241

Apply to the point of screw.

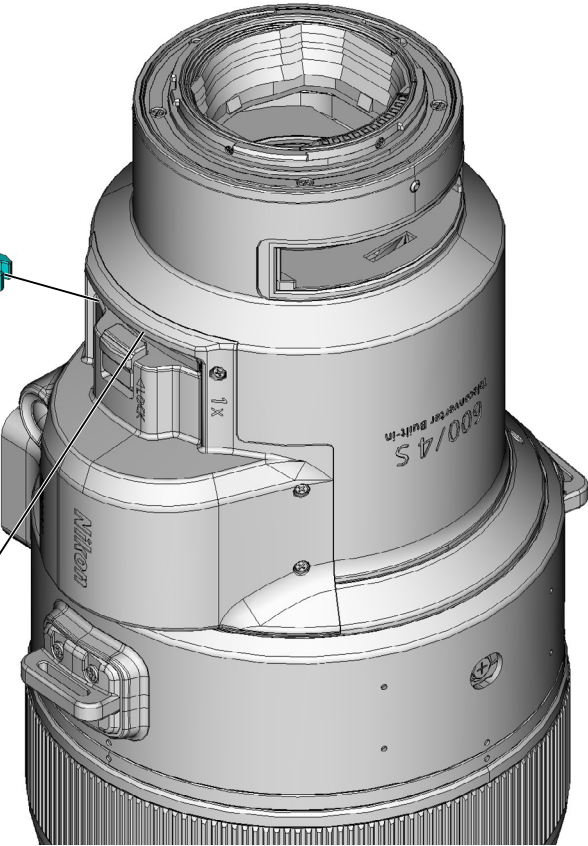

SW UNIT

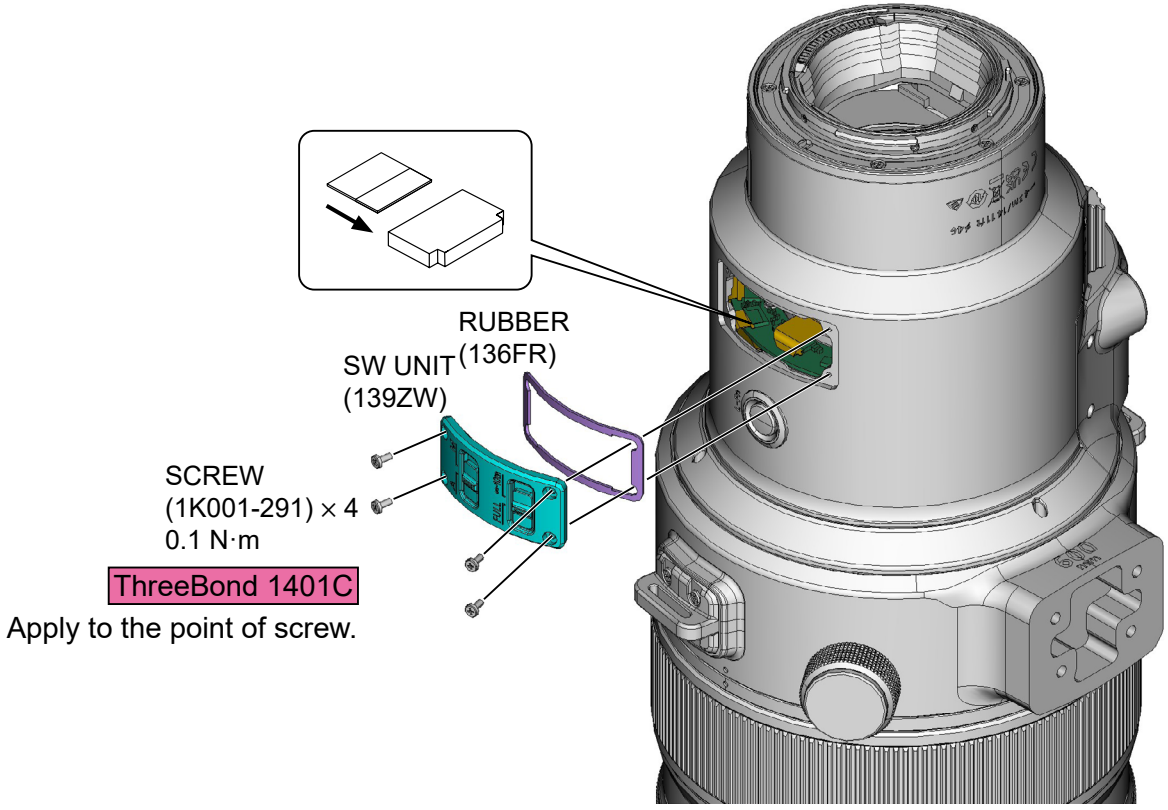

FILTER HOLDER UNIT

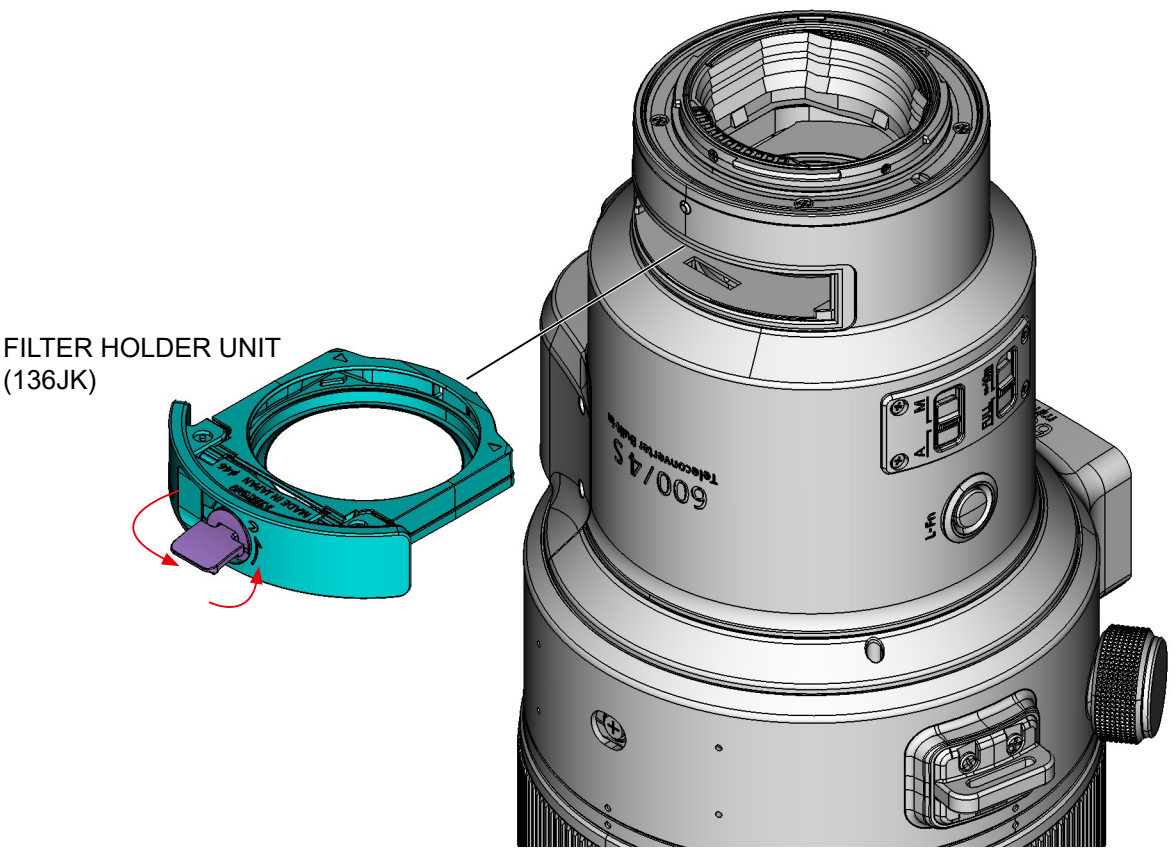

NAME PLATE

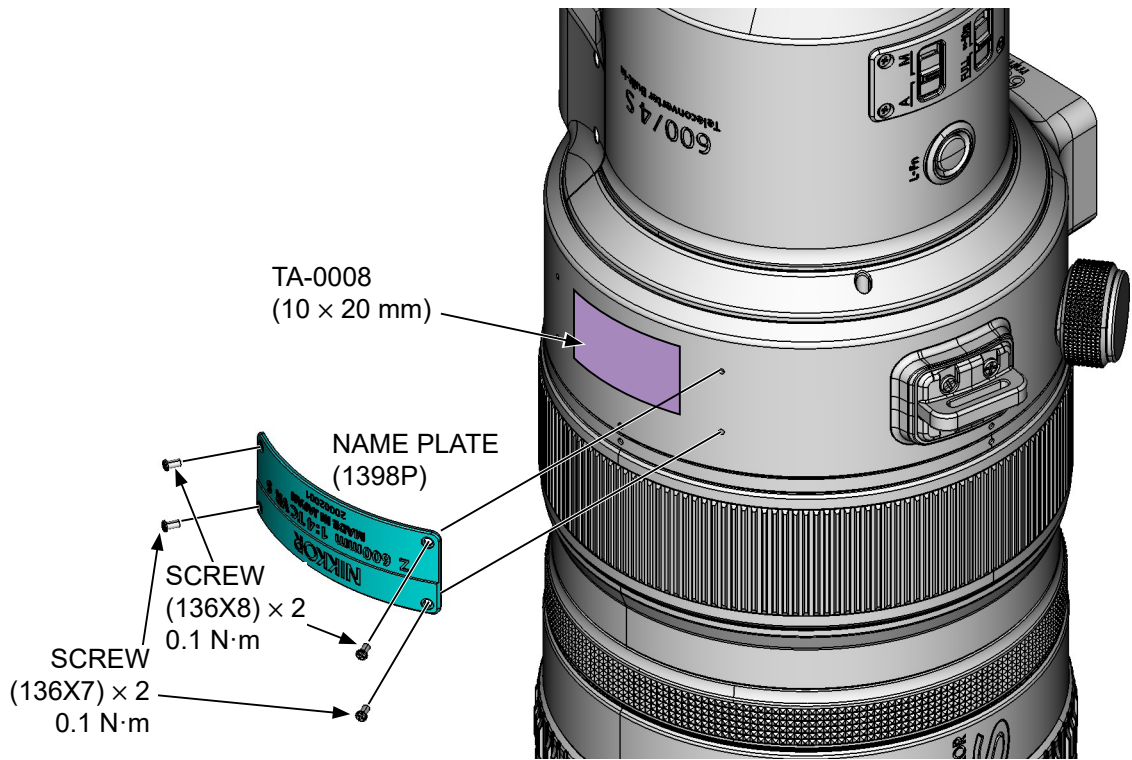

TRIPOD BASE

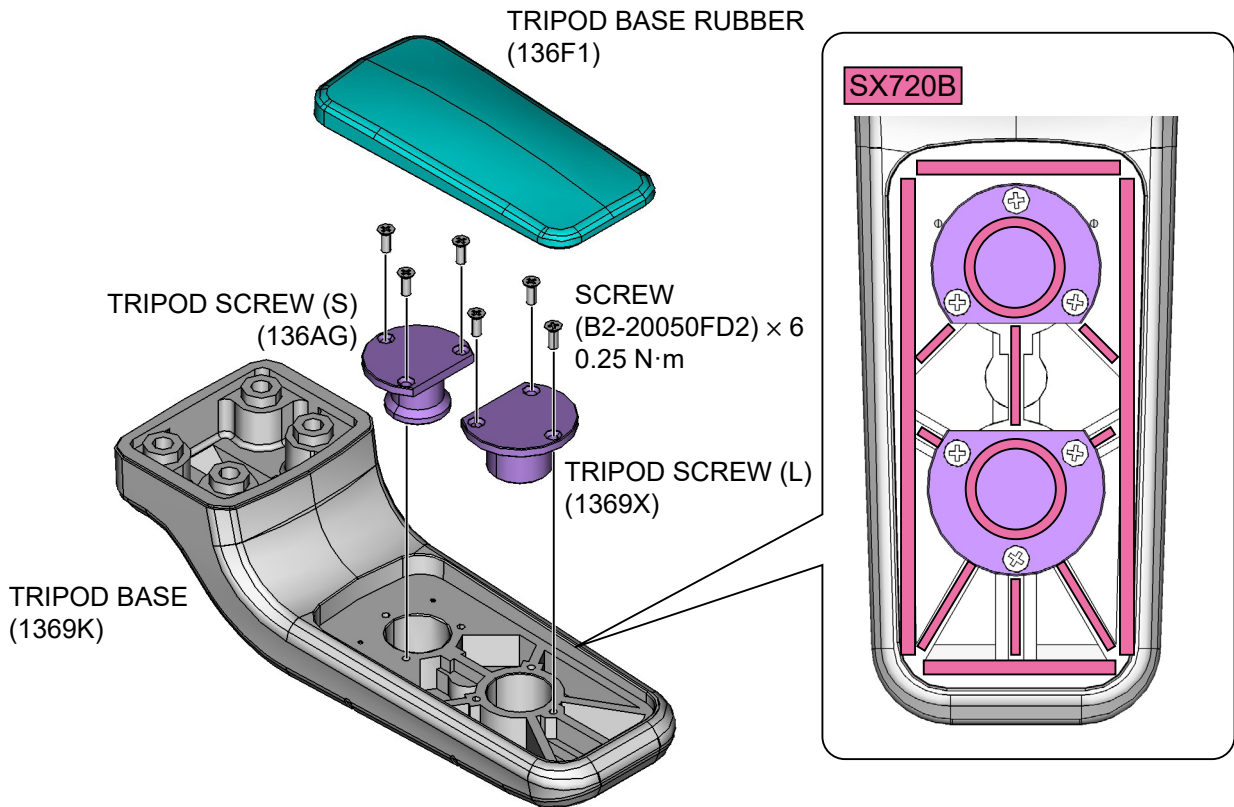

SCREW  
(M1-04010FD2) × 4  
0.4 N·m

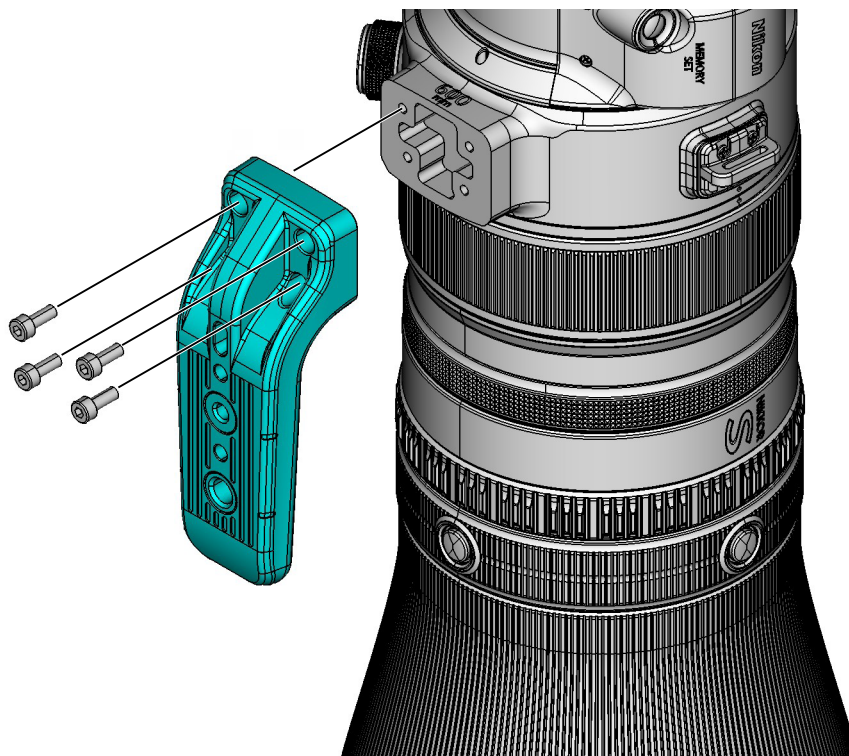

## IMPORTANT

- Perform the following inspection after repairs involving disassembly and assembly.
  - AF Accuracy Inspection Process (P. 43)
  - Control Ring Inspection Process (P. 47)
  - MF Ring Inspection Process (P. 49)

# AF Accuracy Inspection Process

When performing repairs that involve disassembling and reassembling the mount, check the AF accuracy before and after disassembling.

## Tools and parts required:

- Your mirrorless camera
- Tripod
- Indoor lighting (Use the flickerless light.)
- Commercially available focus chart that can measure the focus position
  - Focus charts can be purchased at stores that sell camera-related products or online stores that sell camera-related products.
  - Nikon hereby disclaims all responsibility and liability for any focus charts or other items purchased from third party retailers.

## Camera settings

- The AF accuracy is inspected using your own mirrorless camera, so please make sure that there are no abnormalities in the operation of your camera before starting the inspection.
- When performing an inspection, change the camera settings as shown below.
- Be sure to turn **OFF** "AF Fine Adjustment" as it affects the inspection results.

Set the camera as follows.

For details on the camera settings, refer to the instruction manual of the camera.

## **Camera settings**

- Shooting mode: A mode
- Image quality mode: FINE
- Image size: L
- Aperture: Full open
- ISO sensitivity: 100 to 800 (Automatic sensitivity control OFF)
- White balance: Auto (White priority)
- Picture control: SD (All parameters 0, or clarity 1 or 2)
- AF mode: AF-S
- AF area: Single point AF
- Active D-Lighting: OFF

- Diffraction correction: ON
- Automatic distortion correction: ON
- Vignette control: Standard
- Body VR: OFF
- Exposure delay mode: one to two seconds
- AF fine adjustment: OFF

## **Shooting environment**

Install the camera/lens and chart, referring to the figure below.

Shoot in a location that meets the following requirements:

- Place that is not affected by vibrations
- Place where the brightness can be ensured under indoor lighting.

(Please use flickerless lights.)

### **Example of shooting environment**

The measurement method with a focus chart differs depending on the focus chart you use, so please check the instruction manual for the focus chart you are using.

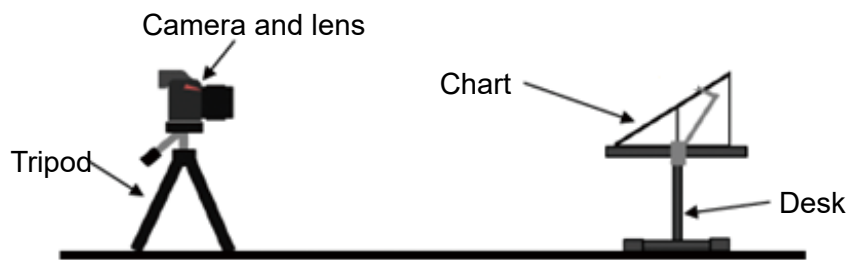

# AF accuracy inspection

Follow the steps below to inspect the AF accuracy.

## Inspection procedure

### 1 Adjust the camera position

1. Adjust the shooting distance so that the entire focus chart is displayed on the screen as shown in the image below.
  - Adjust the position so that the AF area in the center of the camera is aligned with the center of the target chart.

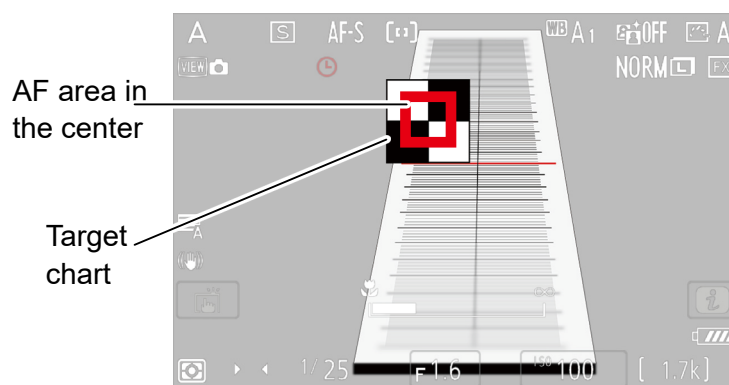

### 2 Check the focus

1. Turn the lens control ring clockwise viewed from the camera to change the focus to the infinity position.
2. Press the release button halfway and check that the chart is in focus.

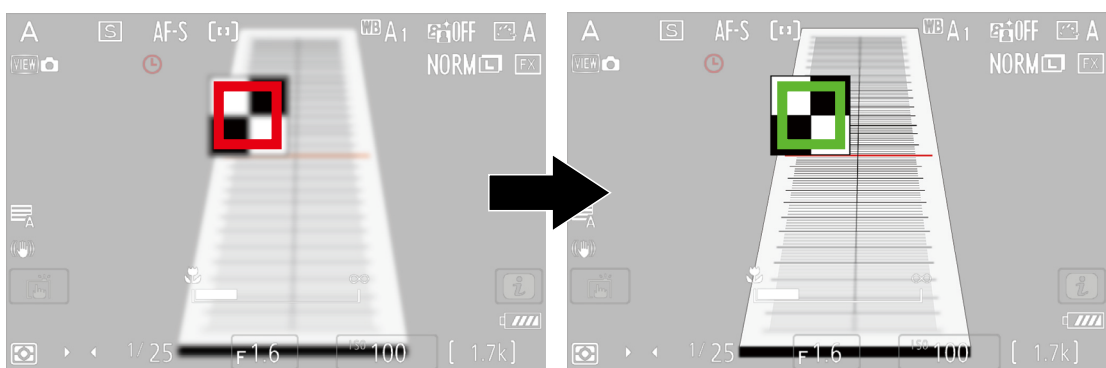

---

### 3 Shoot the chart

1. Press the release button to shoot the target chart.
2. When checking before disassembling, check the inside of the red frame in the image, and record the focus position.

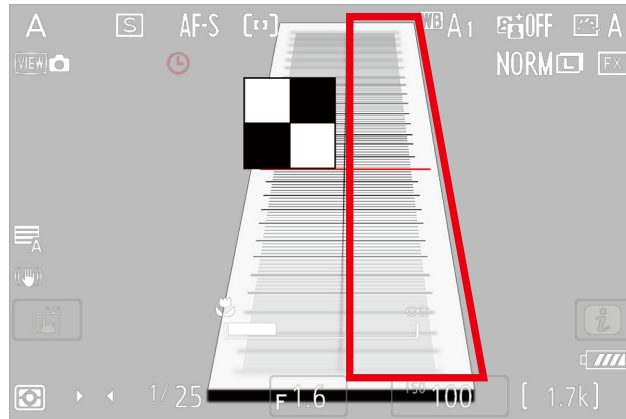

3. When checking after disassembling, confirm that there is no difference from the focus position recorded before disassembling.

 **CAUTION**

- If the focus position is significantly different from what it was before disassembling, we recommend that you disassemble and repair the Product again.

# Control Ring Inspection Process

When performing repairs that involve disassembling or reassembling the mount, inspect the control ring.

## Tools and parts required:

- Your mirrorless camera

## Control ring inspection

Follow the steps below to perform a control ring inspection.

## Inspection procedure

### **1 Check the functions assigned to the control ring**

1. From the camera MENU, select [Custom Menu] - [f Operation] - [f2 Custom controls(shooting)].
  - The setting names may differ depending on the camera model.
2. Check the functions assigned to the control ring.
  - In the example below, confirm that "Aperture" is set.



The setting names may differ depending on the camera model.

- If no function is set on the control ring, set one of the following functions.

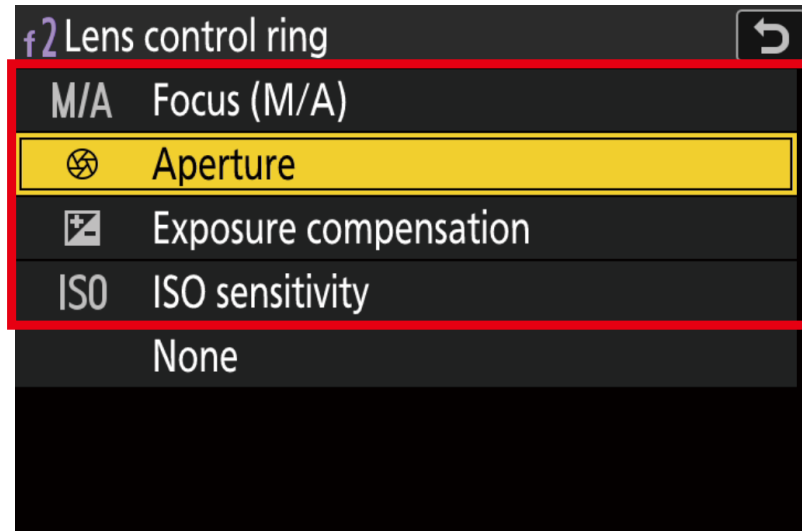

The setting names may differ depending on the camera model.

---

## 2 Check the operation of the control ring

1. Rotate the lens control ring and check whether the assigned function is working.
  - **Focus (M/A):** Check that the focus operation is performed.
  - **Aperture:** Set the exposure mode to A mode or M mode, and check that the aperture changes.
  - **Exposure compensation:** Check that the exposure compensation changes.
  - **ISO sensitivity:** Check that the ISO sensitivity changes.

# MF Ring Inspection Process

When performing repairs that involve disassembling or assembling the mount, inspect the MF ring.

## Tools and parts required:

- Your mirrorless camera

## MF ring inspection

## Inspection procedure

---

**1 Attach the lens to your mirrorless camera.**

---

**2 Rotate the MF ring and check that the focus function works.**

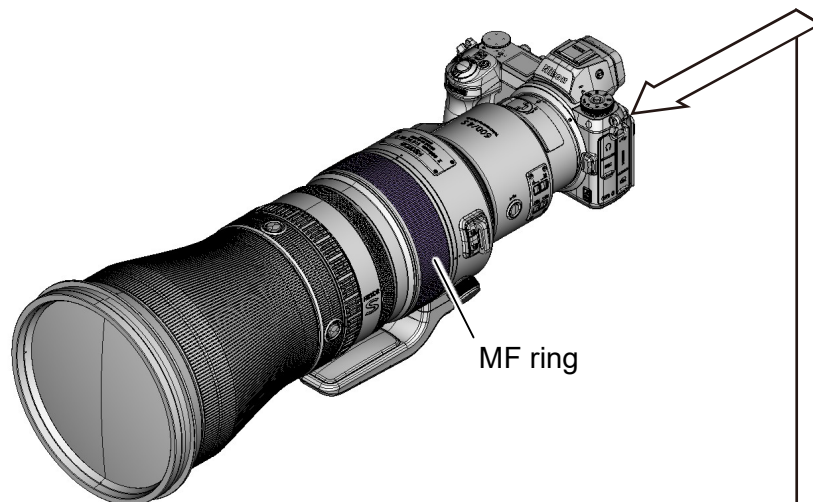

While watching the camera monitor, check that focus positions change.

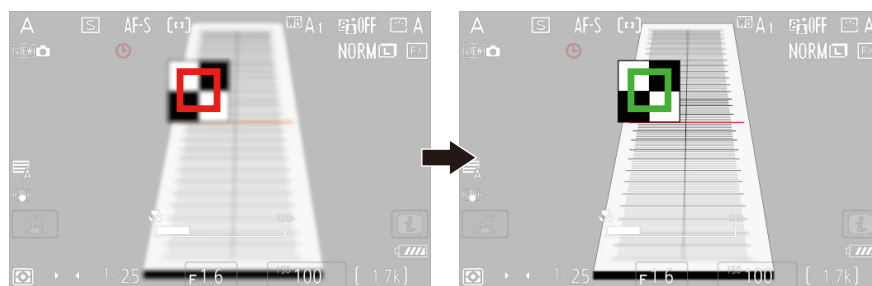

No reproduction in any form of this document, in whole or in part (except for brief quotation in critical articles or reviews), may be made without written authorization from NIKON CORPORATION.

Out of concern for the environment, Nikon is working to reduce its use of paper.

**NIKON CORPORATION**

---

© 2024 Nikon Corporation